

plug-in, electronic digital thermostat with defrost control



User manual

**→ LEGGI E CONSERVA
QUESTE ISTRUZIONI ←**
**→ READ AND SAVE
THESE INSTRUCTIONS ←**

CAREL
Technology & Evolution

**LEGGI E CONSERVA
QUESTE ISTRUZIONI**

**READ AND SAVE
THESE INSTRUCTIONS**

We wish to save you time and money!

We can assure you that a thorough reading of this manual will guarantee correct installation and safe use of the product described.

IMPORTANT



BEFORE INSTALLING OR OPERATING ON THE DEVICE, CAREFULLY READ THE INSTRUCTIONS IN THIS MANUAL.

This instrument has been designed to operate without risks only if:

- Installation, operation and maintenance are performed according to the instructions of this manual;
- Environmental conditions and supply voltage fall within the values indicated here below;

Any different use or changes which have not been previously authorised by the manufacturer, are considered improper. Responsibility for injuries or damage caused by improper use will fall exclusively on the user.

Warning: voltage is present in some electrical components of this instrument, thus all the service or maintenance operations must be performed by expert and skilled personnel only, aware of the necessary precautions to be taken.

Before accessing the internal parts, disconnect the power supply.

Disposal of the instrument:

The controller is made up of metal and plastic parts. All these components must be disposed of according to the standards in force in your own country.

CONTENTS

INTRODUCTION	30
1. GENERAL CHARACTERISTICS	4
1.1 Models available	4
1.1.1 PJ32S	4
1.1.2 PJ32Y - PJ32X	4
1.1.3 PJ32C	4
1.2 Characteristics	5
2. HARDWARE STRUCTURE	6
2.1 Meaning of the inputs and outputs	6
2.2 Instrument and accessory codes	7
2.2.1 Codes for the instruments in individual packaging	7
2.2.2 NTC and PTC probes	8
2.2.3 Accessories	8
2.3 User interface, meaning of operating indicators and LED display	9
2.3.1 Using the keypad	9
3. INSTALLATION	10
3.1 Mechanical installation	10
3.2 Electrical connections	10
3.2.1 Power supply	10
3.2.2 Special warnings	11
3.2.3 General warnings – installation and connection environments	11
3.2.4 Electrical connections, PJ32	13
3.3 Setting the main operating parameters	14
3.4 Table summarising the parameters to be checked before installation	15
4. PARAMETERS - DESCRIPTION	16
4.1 The configuration parameters	16
4.2 Classification of the parameters	16
4.3 The password PS	16
4.4 / = temperature probe management parameters	16
4.5 r = temperature control parameters	17
4.6 c = compressor management parameters	18
4.7 d = defrost management parameters	20
4.8 A = alarm management parameters	22
4.9 F = evaporator fan management parameters	25
4.10 H = other settings	27
5. OPERATING STATES	28
6. PARAMETERS - MODIFICATION	29
6.1 Modifying the set point and differential	29
6.2 Accessing the parameters	29
6.3 Modifying the parameters	30
6.4 Saving the new values assigned to the parameters and exiting	30
6.5 Exiting the procedure without modifying the parameters	30
6.6 Parameters – summary table	30
7. ALARMS, TROUBLESHOOTING	32
7.1 Anomalous or special operating conditions	32
7.2 Description of the main signals and alarms	32
7.3 Data error	33
7.3.1 Loading the default parameters	33
7.4 Troubleshooting	34

8.	AVAILABLE ACCESSORIES	35
8.1	Key for copying the parameters	35
8.2	Serial adapter for RS485 network	36
8.2.1	General characteristics	36
8.2.2	Installation	37
8.2.3	Setting the operating parameters	37
8.2.4	Serial adapter parameters	37
8.3	Additional HACCP module	39
8.3.1	General characteristics	39
8.3.2	Installation	39
8.3.3	Setting the main operating parameters	39
8.3.4	Parameters - description	40
8.3.5	Parameters of the plug-in instrument	40
8.3.6	HACCP module parameters	40
8.3.7	Parameters corresponding to the recording of the HA and HF alarms	42
8.3.8	Operating mode and alarm signals	42
8.3.9	Cancelling the alarms	43
9.	TECHNICAL SPECIFICATIONS	44
9.1	Table summarising the characteristics of the relays used	45
9.2	Temperature/resistance values for the NTC thermistors	45
10.	DIMENSIONS	46

INTRODUCTION

The new plug-in family for refrigeration is made up of a new series of microprocessor-based electronic controls with LED display, designed for the management of display case and showcase refrigeration units.

A range of models is available, providing the best solution for all applications, at the most competitive price.

The plug-in family builds on the experience and success of the previous product ranges, such as the IR32 and IR32E, with the aim of offering an increasingly simple and economical product, without relinquishing on the performance required by the refrigeration manufacturer.

The structure of the parameters and the operating logic has remained from the IR32E range, a number of functions have been simplified, and extra performance has been added. The main characteristics are:

- external RS485 serial interface, optionally connected to the instrument;
- display in degrees (centigrade or Fahrenheit), using display with two digits and minus sign;
- complete range with models featuring 1, 2, 3 relays;
- ergonomic three-button keypad.

Furthermore, new functions and characteristics have been introduced:

- probe inputs for NTC or PTC (different codes);
- display of operating status (cooling - defrost - alarm), using a clearly visible and easily recognisable signal, thanks to the three buttons with back-lighting;
- highly-efficient red LED display;
- innovative system for fastening the instrument from the front panel, using two screws;
- front frames in various colours, customised upon request;
- external options available, such as: HACCP module and optically-isolated RS485 serial module;
- quick programming of the control, using hardware key, even when the instrument is not powered;
- possibility to modify the list of parameters, selecting each parameter as a frequently-used or password-protected parameter;
- electrical connections using removable (screw or crimped) or fixed screw connectors;
- power thermostat version with 12A resistive relay;
- complete range with power transformer for the 115 to 230Vac versions.

1. GENERAL CHARACTERISTICS

1.1 Models available

The various models are differentiated according to the following functions and performance:

- operating mode and number of inputs and outputs for versions S, Y, X and C;
- complete versions (hereafter: **Top**) with serial connection, fastening from front panel, removable terminals;
- compact versions (hereafter: **Eco**) with fixed terminals and fastening only using rear bracket, and without serial connection;
- the power supply can be one of the following: 230Vac, 115Vac or 12Vac/Vdc;
- the field of measurement for all models is from -50 to 90 °C (-50 to 127 °F), with resistive NTC probe;
- a PTC probe is available with the same field of measurement, for one model only (PJ32S **Eco**);
- digital input from free contact: in models where featured it is an alternative to the second probe;
- relay outputs: available with three different current ratings, 5A, 8A and 12A (for resistive load);

1.1.1 PJ32S

This represents the ideal solution for the management of static refrigeration units (that is, without fan on the evaporator), operating at normal temperature (above 0°C). This instrument, in fact, performs the functions of thermometer, displaying the temperature of the unit, and electronic thermostat, activating the compressor (or the electrovalve in the case of multiplexed units) so as to maintain the required temperature. Furthermore, it handles automatic defrost using the forced shut-down of the compressor, and safety functions through management of the time settings.

- All the S models use just one probe for the control functions (AMB. T.), and feature a changeover relay contact for the control of the actuator (COMPRESSOR).
- In some models (PJ32S00 or S0P) a second probe can be connected to display the product storage temperature; this probe does not affect control.
- There is a model (PJ32S20) with a digital input and two relay outputs: actuator control and output alarm with changeover contact.
- The models (PJ32S0P and S1P) use a 12A resistive relay with changeover contact. In all the other models the relay is 8A resistive;
- There are a significant number of versions, both **Top** and **Eco**, with 230V, 115V and also 12V power supply.

1.1.2 PJ32Y - PJ32X

These are designed for the management of static units operating at low temperature (that is, below 0°C), which require 'active' defrost using electrical heating elements or the injection of hot gas. The PJ32Y or X, in fact, as well as working as a thermometer and a thermostat like the S model, also manages the defrost actuator. The frequency and duration of the defrost can be set. The end defrost can occur according to the temperature reached (connecting a probe to the evaporator) or by time.

- The Y models feature two probe inputs, for control (AMB. T.) and for defrost (DEF. T.).
- The X models, on the other hand, feature just one probe and a digital input; for these models, timed defrost is compulsory.
- There are two relay outputs for the control of the actuator (COMPRESSOR) and for DEFROST control, with changeover contacts, the relays used are 8A resistive.
- Almost all models feature removable terminals (**Top**), with 230 or 115V power supply. There is just one Y model (**Eco**) with 12V power supply.

1.1.3 PJ32C

These represent the most complete solution for ventilated units operating at low temperature. In these models, there are three relays, providing complete control of the compressor, fan and defrost management functions. The three 8, 5 and 5A resistive relays have been built into a very compact case in the versions which also feature the 230V or 115V power transformer, and without compromising the performance or the reliability of the product.

- There are two probe inputs for control (AMB. T.) and for defrost (DEF. T.).
- There are three outputs: the 8A resistive compressor relay, defrost, and 5A resistive for the fans.
- All versions have removable terminals (**Top**) and 115Vac and 230Vac power supply.

1.2 Characteristics

Power supply

The plug-in can be powered at: 230Vac or 115Vac using an internal transformer, or at 12Vac/Vdc without internal transformer.

Aesthetics and ergonomics

The LED signals are clearly visible by the backlighting of the three buttons or 3 symbols on the display. The front panel frame can be customised both in terms of colour and indications.

LED display

The temperature and the parameter settings are displayed by '**two and a half digits**'. For the temperature values, the field of display is from -50T127 degrees centigrade or Fahrenheit. For the parameters, the field of display can be from -99 to +199, or from -127 to +127. The 3 status signals represent the activation of an actuator (normally a compressor), the defrost function or an alarm.

Alarm buzzer

The controls with one relay only can be fitted as standard with a buzzer for signalling alarms.

Duty setting and continuous cycle

Functions are:

- the activation of the compressor with programmable timers in the event of control probe fault.
- continuous cycle, which forces the activation of the compressor for the programmable time.

Multifunction input

The digital input, when present, can be used to enable/disable/end the defrost, and to manage serious alarms which require the immediate (e.g. high pressure) or delayed (e.g. low pressure) shut-down of the unit.

Connections

The economical versions (**Eco**) maintain the traditional fixed terminals, while the complete versions (**Top**) use removable terminals. The latter significantly simplify the installation and maintenance of the machine.

Relay outputs

There are, according to the model, up to three relays for the control of **compressors, defrost, fan** and **alarms**. When more than one relay is fitted, the common of all the relays is connected and is available on just one terminal.

Multifunction output

The alarm relay output, when present, can be set using a parameter to be normally activated or normally deactivated.

Keypad and parameter protection

The keypad can be disabled to avoid tampering by unauthorised persons. For each parameter, furthermore, the level of possible modification, with or without PASSWORD, can be set.

Serial connection

The **Top** versions feature serial connection, with the following external options:

- parameter copy key: allows the parameters to be duplicated and configured;
- HACCP module, used to record temperatures and alarms;
- RS485 serial adapter module, for connection to a supervisor.

Display of second probe

In the models with two probes, the measurement of the second probe can be displayed instead of the first (control probe). This function can be used to display the product storage temperature; the defrost mode, in this case, is only by time.

Fastening

The fastening method used for the economical models (**Eco**) uses a rear-panel fastening bracket, while all the other versions (**Top**) also feature the possibility of fastening **from the front panel**, using two screws.

Electromagnetic compatibility

The plug-in series conforms to EU standards on electromagnetic compatibility:

- for appliances for domestic use EN55014-2 and EN55014-1;
- for residential, commercial and light industrial environments EN50082-1 and EN50081-1
- for industrial environments EN50082-2 and EN50082-1.
- Regarding safety, it conforms to standards EN60730-1 and EN60730-2-9.



The CE mark confirms the quality and the safety of the plug-in series, guaranteed by the CAREL ISO 9001 certified design and production system.

2. HARDWARE STRUCTURE

The instruments in the PJ32* series are temperature controls used to manage refrigeration units (showcases and display cases).

An application diagram is shown in the figure; also indicated are the possible accessories and expansion modules, as well as the connections for the inputs and outputs:

1. instrument;
2. plug-in frame;
3. temperature probes;
4. power transformer (according to the models);
5. RS485 serial adapter module;
6. HACCP module;
7. parameter programming key.

This manual describes the characteristics of the instrument, and only briefly mentions the accessories and expansion modules. The connection of the RS485 or HACCP expansion modules is mutually exclusive.

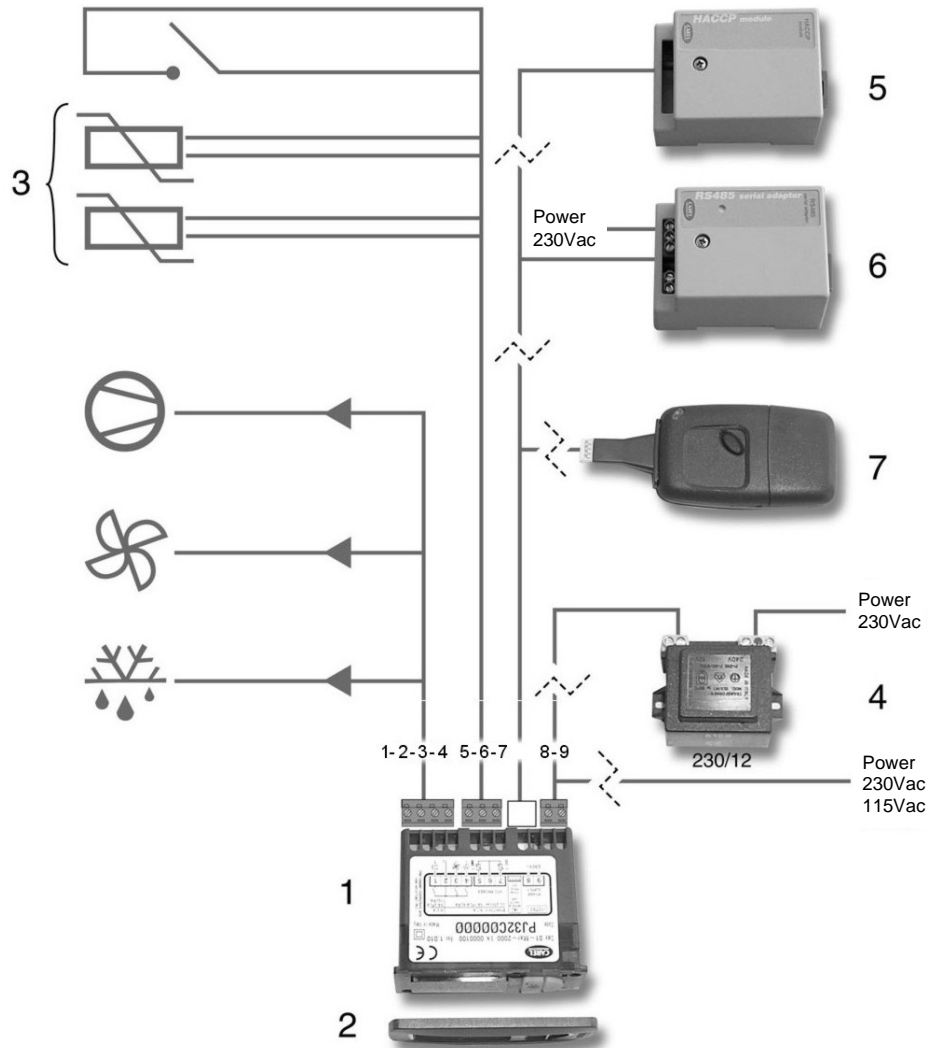

Fig. 2.1

2.1 Meaning of the inputs and outputs

	description (numbering of terminals, with reference to Fig. 2.1)
POWER SUPPLY	terminals 8 and 9; the value of the power supply can be 230Vac, 115Vac or 12Vac/Vdc. The effective value is indicated on the connection label
temperature probes	terminals 5 and 6 are for the ambient temperature probe (control) terminals 6 and 7 are for the defrost temperature probe (defrost), when featured according to the code, connection is for standard CAREL NTC or PTC probes
digital input	terminals 6 and 7 are for the digital input from free contact, when featured
relay outputs	the group of terminals numbered 1, 2, 3, 4 are for the connection of the relay outputs. The assignment of the outputs can change according to the code, the effective assignment is indicated on the connection label. - For instrument codes with one relay only, the changeover contact is available for compressor control, using terminals 1, 2, 3. - For instrument codes with two relays, the changeover contact is available for defrost control, on terminals 1, 2, 3, and the closing contact for the compressor relay, on terminals 3 and 4. Terminal 3 is common for the two relays, thus the current at the terminal will be the sum of the two. - For instrument codes with three relays, terminal 1 is used for the compressor control, terminal 3 for fan control, terminal 4 for defrost control and terminal 2 is the common of all three relays. The current at terminal two will be the sum of the three outputs.
serial connection	the four-pin connector is for connection to the RS485 serial and HACCP adapters, and for connection of the parameter copy key. This connection is not present on the Eco models

Tab. 2.1.1

2.2 Instrument and accessory codes

The definition of the instrument codes is based on two categories: one for the simpler and more economical versions (**Eco**), and one for the versions complete with all functions (**Top**). The main differences between the two versions are that the following are present only in the **Top** versions:

- removable terminals in the place of fixed terminals;
- fastening from front panel using screws;
- serial connector present, with the possibility to connect expansion modules and to the key.

Warning: the options indicated **are not** all freely modular, and so to avoid incompatibility, product codes have been defined which cover the needs of the market. Customised versions can only be produced if they are compatible with the internal limits of the instruments and according to adequate quantities and the kit requirements.

The front panel frame is supplied in grey (standard for the single instrument), it can be customised in terms of colour and text, and can thus be ordered separately or in a kit.

2.2.1 Codes for the instruments in individual packaging

Eco models with 1 relay: 1 probe, fixed terminals	code
PJ32S 12Vac/Vdc - NTC -no options- screw terminals relay 8A SPDT	PJ32S0EL00
PJ32S 230Vac - NTC -no options- screw term. relay 8A SPDT	PJ32S0E000
PJ32S 110Vac - NTC -no options- screw term. relay 8A SPDT	PJ32S0E100
PJ32S 230Vac - PTC -no options- screw term. relay 8A SPDT	PJ32S6E000

Tab. 2.2.1

Top models with 1 relay: 1 or 2 probes, removable terminals, serial connection	code
PJ32S 230Vac - 1(2)NTC - removable terminals relay 8A SPDT (*)	PJ32S00000
PJ32S 110Vac - 1(2)NTC - removable terminals relay 8A SPDT (*)	PJ32S00100
PJ32S 230Vac - 2 NTC - removable terminals-16A SPDT - buzzer (*)	PJ32S0P000
PJ32S 230Vac - 1 NTC - removable terminals-16A SPDT – dig. input - buzzer	PJ32S1P000
PJ32S 110Vac - 2 NTC - removable terminals-16A SPDT - buzzer (*)	PJ32S0P100
PJ32S 110Vac - 1 NTC - removable terminals-16A SPDT – dig. input - buzzer	PJ32S1P100

Tab. 2.2.2

(*) the S models with two probes, PJ32S00* and PJ32S0P*, have been designed only to use the second probe for the measurement and display of the food storage temperature (Food Probe). To manage the second probe these models are in reality programmed as Y models, with all the corresponding parameters, yet without the defrost relay; it is clear that they must be set so as not to use the defrost function or, if necessary, timed defrost only (**d0**=2 for timed defrost, **dI**=0 for no defrost or **dI**>0 for cyclical defrost).

Top models with 1 relay + 1 alarm relay, 1 probe, dig. input, serial connection	CODE
PJ32S 230Vac - NTC - removable terminals - comp. relay(8A NO) + alarm (8A SPDT) (**)	PJ32S20000
PJ32S 110Vac - NTC - removable terminals - comp. relay(8A NO) + alarm (8A SPDT) (**)	PJ32S20100

Tab. 2.2.3

(**) the S models with alarm relay, PJ32S20*, to use the function for programming the status of the alarm relay using parameter **H1**, are programmed as X models; as they do not have the defrost relay, they must be programmed so as not to use the defrost function or, if necessary, timed defrost only (see (*) Tab. 2.2.2).

Eco models with 2 relays: 2 probes, 2 8A relays, fixed terminals	code
PJ32Y 12Vac/Vdc - 2 NTC - comp. relay (NO) + defrost (SPDT)	PJ32Y0EL00

Tab. 2.2.4

Top models with 2 relays: 1 / 2 probes, 2 8A relays, removable terminals, serial conn.	code
PJ32Y 230Vac – 2 NTC probes - comp. relay (NO) + defrost (SPDT)	PJ32Y00000
PJ32X 230Vac - 1 NTC probe - 1 digital input - comp. relay (NO) + defrost (SPDT)	PJ32X10000
PJ32Y 110Vac - 2 NTC probes - comp. relay (NO) + defrost (SPDT)	PJ32Y00100
PJ32X 110Vac - 1 NTC probe - 1 digital input - comp. relay (NO) + defrost (SPDT)	PJ32X10100

Tab. 2.2.5

Top model with 3 relays: 2 probes, removable terminals, serial connection	code
PJ32C 230Vac - 2 NTC - comp. relay (8A NO) + defrost (5A NO) + fan (5A NO)	PJ32C00000
PJ32C 110Vac - 2 NTC - comp. relay (8A NO) + defrost (5A NO) + fan (5A NO)	PJ32C00100

Tab. 2.2.6

WARNING: the versions of instrument with display colours other than red are currently not available.

2.2.2 NTC and PTC probes

All PTC and NTC probes conforming to the CAREL standard can be used, with resistance values of 985 Ω at 25°C, for PTC, and of 10 k Ω for NTC. Below are some codes of the more common versions.

description	operating range	index of protection	CODE
NTC probe, 6x15 mm bulb, plastic,	-50T50°C	IP67	NTC0**HP00
NTC probe, 6x40 mm bulb, metal	-50T100°C	IP67	NTC0**W*00
PTC probe, 6x40 mm bulb, metal, 1.5m long	-50T100°C	IP67	PTC015W000
NTC probe, wall-mounting	-10T70°C	IP30	ASWT011000
NTC probe, duct	-10T70°C	IP40	ASDT011000

Tab. 2.2.2.1

2.2.3 Accessories

Transformers (only for instruments with 12Vac power supply).

description	code
TRA 12: 3 VA, 240/12Vac without fuse on the primary	TRA12VDE00
TRA 12: 3 VA, 240/12Vac with fuse on the primary	TRA12VDE01

Tab. 2.2.3.1

Serial adapters

description	code
optically-isolated RS485 serial module	PJOPZ48500
additional module for HACCP	PJOPZHACPO

Tab. 2.2.3.2

Programming key

description	code
programming key for plug-in	PJOPZKEY00

Tab. 2.2.3.3

Plug-in frames in various colours

description	code
pack of 30 frames, GREY (STANDARD)	PJOPZFG000
pack of 30 frames, BLUE	PJOPZFB000
pack of 30 frames, RED	PJOPZFR000
pack of 30 frames, WHITE	PJOPZFW000
pack of 30 frames, YELLOW	PJOPZFY000
pack of 30 frames, ALUM. METAL	PJOPZFMA00
pack of 30 frames, BLUE METAL	PJOPZFMB00
pack of 30 frames, GOLD METAL	PJOPZFMG00
pack of 30 frames, STEEL METAL	PJOPZFMS00

Tab. 2.2.3.4

Codes for kits: if requested by the customer and the quantity supplied is sufficient, the plug-in instruments can be packaged in multiples of 10. The kit also allows the instrument the ordered together with the options and accessories used by customer in the application. Customised programming of the parameters can also be requested.

The kit codes are defined according to customer request.

WARNINGS:

- the kits are packs of 10 instruments with the corresponding accessories; orders must indicate the total quantity of instruments required (not the number of packs); the quantity ordered must be a multiple of 10, as partial packs are not supplied;
- the quantity of each component in the kit is 10 units, except for the instruction sheet, which can be ordered in single quantities;

2.3 User interface, meaning of operating indicators and LED display

Figs. 2.3.1 and 2.3.2 shows the front panel of the plug-in: display and buttons. The front panel of the instrument features a three-digit display (ref. 4) and three LEDs for backlighting the buttons (refs. 1, 2 and 3 in Fig. 2.3.1), or alternatively three graphic symbols inside the area of the display (refs. 1, 2 and 3 in Fig. 2.3.2).

These indicate:

① this LED indicates the **status (on or off)** of the actuator controlled, (normally a compressor); the button is back-lit by a green LED and is available only on the **Top** models. the button is backlit by LED or the graphic symbol  appears on the display.

The status of the LED can be the following, to indicate:

always on	COMPRESSOR IN OPERATION
continuous flashing	request pending for compressor activation
flashing with 2 cycles and a pause	continuous cycle on

Tab. 2.3.1

② **Alarm signal:** the button is backlit by LED or the graphic symbol  appears on the display.

③ **Defrost in progress:** the button is backlit by LED or the graphic symbol  appears on the display.

LED. The status of the LED can be:

always on	defrost in progress
continuous flashing	request pending for defrost

Tab. 2.3.2

④ **THE LED DISPLAY SHOWS ONE OF THE FOLLOWING PIECES OF INFORMATION, ACCORDING TO THE FUNCTION IN PROGRESS:**

- in normal operation: value measured by the ambient probe or the second probe;
- when setting parameters: code of the parameter or the associated value;
- during an alarm event: flashing code of the alarm detected, alternating with the temperature value.

The temperature measured by the probe is displayed with resolution to a degree (°C or °F). The display range for the temperature is: -50T90 °C (or -50T127 °F). For the parameters, the values can vary from -99 to +199 and in some cases from -127 to +127. The unused segments of the left-most digit are normally always off; expansion modules (Serial 485 and HACCP) can be used to signal states or parameter programming modes. For a complete description please refer to the expansion module manual.

2.3.1 Using the keypad

Three buttons (5, 6 and 7 in Fig.2.3.1) are used to perform the activation and deactivation of the instrument's operating states and set the parameters. The use of the buttons can be divided into two different situations: one in of normal operation, and the other to modify the parameters. For each button, the following are the possible actions associated with both possibilities.

⑤ In **normal operation** and if pressed for more than 5 seconds:

- activates/deactivates continuous cycle (compressor).

In **modify parameter** mode:

- moves from one parameter to the next;
- increases the value of the parameter.

⑥ In **normal operation:**

- silences the audible alarm (only if featured);
- displays and/or sets the **Set point**;
- if pressed for more than 5 seconds not during an alarm: accesses the menu for setting type 'F' parameters (frequent);

• if pressed when turning on the instrument, together with the  button, activates the parameter RESET procedure.

In **modify parameter** mode:

- displays the value of the selected parameter /exits the display;
- if pressed for more than 5 seconds in modify parameter mode, saves the changes.

⑦

In **normal operation:**

- if pressed for more than 5 seconds: starts a manual defrost, if enabled.

In **modify parameter** mode:

- moves from one parameter to the previous;
- decreases the value of the parameter.

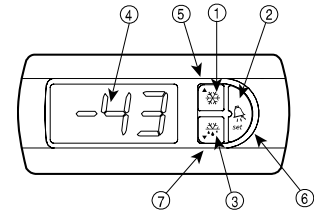

Fig. 2.3.1

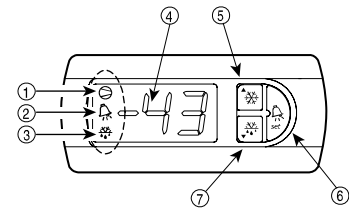

Fig. 2.3.2

3. INSTALLATION

The installation operations for the plug-in controls can be grouped as follows:

1. mechanical installation;
2. electrical connections: probes, power supply and actuators;
3. setting of the operating parameters.

3.1 Mechanical installation

1. Insert the instrument in the previously created hole as per the drilling template, 71x29 mm;
2. for mounting using the bracket (for all **Eco** versions): lock the instrument onto the panel, by sliding the bracket;
3. for mounting using screws from the front panel (only for the **Top** versions): rest the instrument on the front panel and, using the screwdriver tighten the two screws, making sure the two teeth are properly clicked in. The following describes the procedure in detail. The thickness of the fastening panel must not exceed 3 mm;
 - 3.1 remove the front panel frame and check that the two attachment teeth are in their slot (they must not protrude from the dimensions of the drilling template). If necessary, unscrew the two screws, applying pressure. Do not unscrew too much, the screw must not be raised from the front panel;
 - 3.2 connect all the cables to the corresponding terminals or insert the pre-wired removable terminals onto the corresponding connectors;
 - 3.3 insert the instrument in the hole in the panel, placing the connected cables inside, and hold it in position by pressing in the centre of the front panel; using the screwdriver, tighten the lower screw 90°, the tooth must come out of its slot and click onto the panel, then tighten up until the front panel is secure;
 - 3.4 repeat the same operation for the upper screw;
 - 3.5 if the tooth does not click onto the panel (max. thickness 3.0 mm), unscrew the screw, applying pressure at the same time with the screwdriver so that the tooth moves back. As mentioned in point 1, do not unscrew too much, the head of the screw must not be raised from the surface of the front panel;
 - 3.6 the two screws must be tightened with the same pressure, so as to not leave one corner higher than the other. **DO NOT** tighten excessively, **when the front panel is secure simply tighten a further ½ turn to compress the gasket;**
 - 3.7 apply the front panel frame.
4. If having to remove the instrument, proceed as follows:
 - 4.1 unclip the front panel frame;
 - 4.2 unscrew the lower screw, at the moment the front panel leaves the panel keep pressure on the screw and unscrew a further 90° to make the tooth go back into its slot;
 - 4.3 repeat for the upper screw;
 - 4.4 remove the instrument from panel, keeping it horizontal;

WARNINGS: the screwdriver which should be used is the Pozidriv 1 (PZD1) Phillips head screwdriver. **Do not use motorised screwdrivers.**

3.2 Electrical connections

The instruments in the PJ32 series feature different terminals for the connections:

- the Eco versions use the traditional fixed screw terminals;
- the Top versions, on the other hand, feature removable terminals with two types of cable connection blocks: screw, or by crimping.

The versions with removable terminals offer considerably simplified connection of the instrument, both for installation and maintenance. Furthermore, connection errors are avoided, as the three connection blocks have a different number of pins.

3.2.1 Power supply

The plug-in instruments are connected to the power supply using terminals 8 and 9 in the Eco versions, or with the two-way removable block to be inserted in the terminals 8 and 9 for the Top versions.

The voltage supplied to these terminals must correspond, within the tolerance indicated, to the value on the instrument's connection label. The values are 230Vac, 115Vac and 12Vac/Vdc, according to the code.

The electrical insulation featured in the instrument, for the versions with mains power supply (230Vac and 115Vac), corresponds to reinforced insulation. The versions with 12Vac/Vdc power supply do not feature insulation.

To guarantee correct operation during voltage drops, all the plug-in instruments feature low power operation: below a certain threshold the current supplied to the display is gradually reduced, up to the total switching off of the display and LEDs. All the other functions are guaranteed within the maximum allowed voltage drop limits; in particular, the status of the relay is maintained.

On return of the normal power supply conditions, the display and the LED are reset.

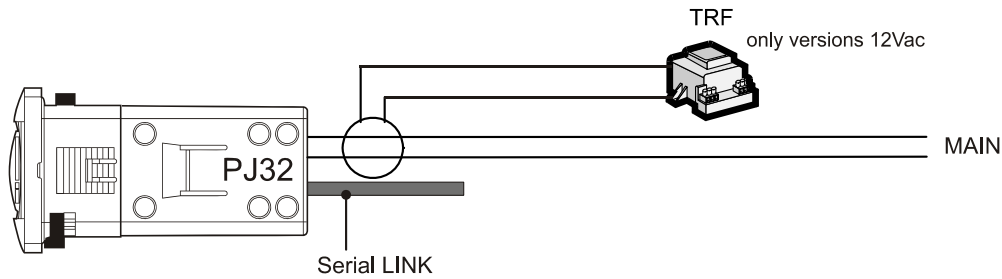

Fig. 3.2.1.1

3.2.2 Special warnings

For the direct connection of the instruments and the layout and checking of the wiring, the following warnings must be carefully read and the diagrams adhered to; errors in connection can cause danger to the safety of the user and damage the instruments and connected components. Also remember that the units must be fitted with all the electromechanical safety devices required to ensure correct operation and the complete safety of the user.

For the 12Vac versions, if the power supply available:

- **is mains power**, a safety transformer is required (CAREL code TRA12VDE01 or TRA12VDE00) to guarantee the double insulation between the power supply and the low voltage electronics inside. If required, the protective fuse placed in series with the primary (32 mA_T, for code TRA12VDE00) is indispensable. The connection between the transformer and the instrument must be as short as possible;
- **is already low voltage, but not 12Vac**, a suitably rated adapting transformer must be used: double insulation between primary and secondary, and suitable surge features on the primary (2000V for applications in industrial environments).
- **is 12Vac**, the instrument can be powered directly, evaluating the following conditions. The power line must not be connected to the actuators and must not be near other connections which may cause high intensity disturbance. In case of doubt, and to guarantee conformity to electromagnetic immunity standards, an insulating transformer, with the characteristics described in the previous point, is recommended.

If more than one control with a 12Vac power supply is connected to the same transformer, the polarity of the wiring must be checked, in the sense that each terminal of the transformer must be connected to the same terminal of all the controls. In this case, conformity to the EMI standards must be evaluated by the manufacturer/installer.

3.2.3 General warnings – installation and connection environments

Avoid mounting the boards in environments with the following characteristics:

- relative humidity over 90% or presence of condensation;
- heavy vibrations or knocks;
- exposure to continuous jets of water;
- exposure to aggressive and polluting atmospheric agents (e.g.: sulphur and ammonia gases, saline mist, smoke) which may cause corrosion and/or oxidation;
- high magnetic and/or radio-frequency interference (thus avoid installation near transmitting antennae);
- exposure to direct sunlight and atmospheric agents in general;
- large and rapid fluctuations in ambient temperature;
- environments where explosives or mixes of inflammable gases are present;
- exposure to dust (formation of corrosive patina with possible oxidation and reduction of insulation);

These warnings must be **followed** for connection:

- electrical power supply other than that prescribed may seriously damage the system;
- use cable ends that are suitable for the terminals. Loosen each screw and insert the cable end, then tighten the screws. On completing the operation, tug the cables lightly to check they are sufficiently tight;
- separate the probe signal and digital input cables from inductive loads and power cables as much as possible, to avoid any electromagnetic disturbance. **Never lay power cables and probe cables in the same cable channels (including those for the electrical cables).** Do not install the probe cables in the immediate vicinity of power devices (contactors, thermo-magnetic devices or other);
- reduce the length of the sensor cables as much as possible, and avoid spirals around power devices. The probes must be connected using shielded cables (minimum cross-section for each lead: 0.5 mm²);
- the probes can be installed up to a maximum distance of 100m from the control. To extend the distance of the probes, use cables with a minimum cross-section of 1 mm², shielded where possible. In this case, the shield must be connected to the common of the probe. Do not earth the other end of the shield (the sensor end);
- only use IP67 probes as end defrost probes; place the probes with the vertical bulb upwards, so as to assist the drainage of any condensation. Remember that the thermistor temperature probes (NTC or PTC) have no polarity, so the order of connection of the ends is not important;
- avoid direct contact with the internal electronic components.

Wiring diagrams for multiple units, wiring examples for the serial connection of the instruments:

- MAIN: mains power supply, 230 or 115Vac;

- Serial: serial connection to the supervisor system;
- TRF: 3VA transformer.

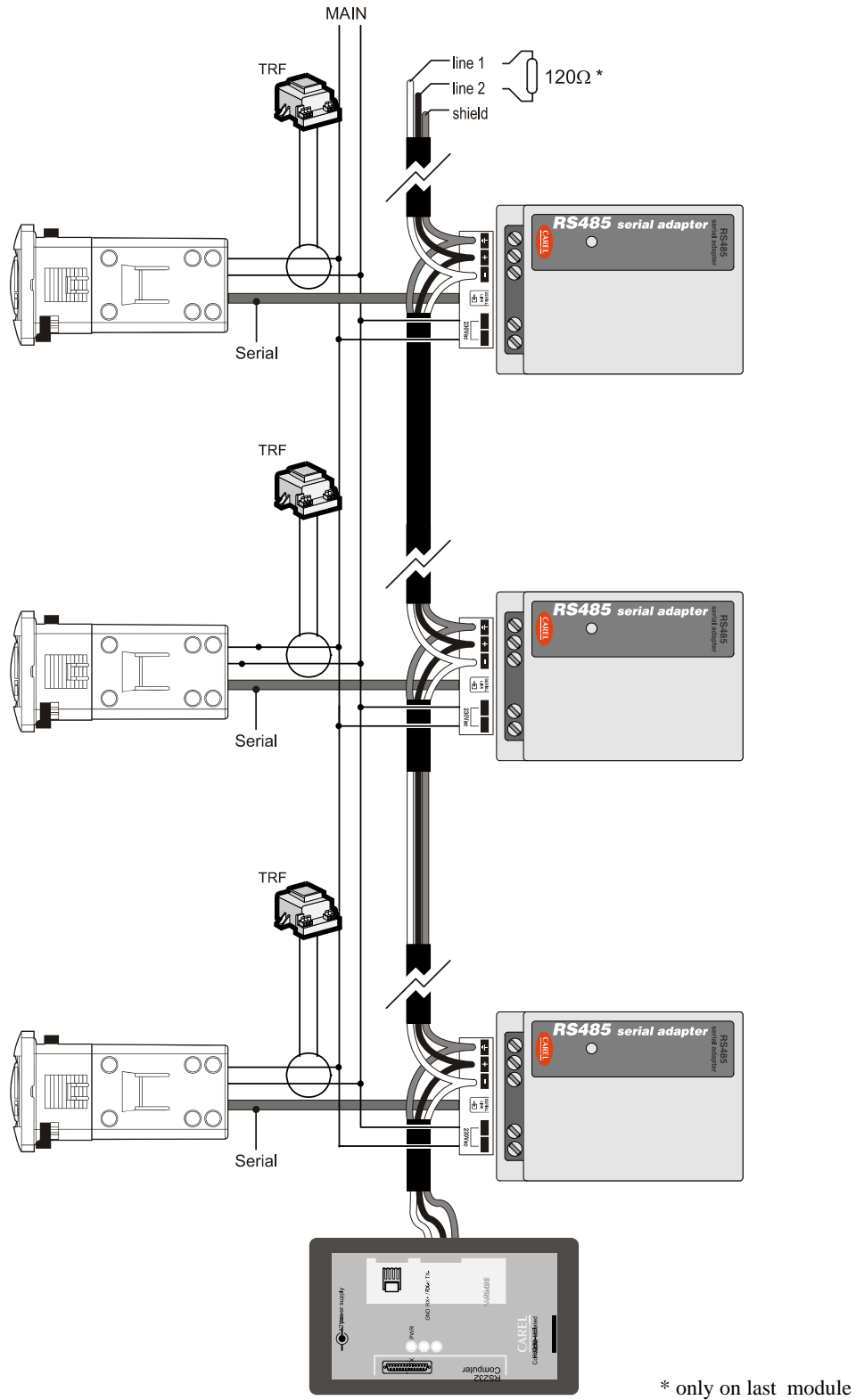

Fig. 3.4.2.1

WARNING: the diagrams show the serial connection including the RS485 serial interface adapter (see options) which is external to the instrument and must be powered separately. Versions with 115 and 230 Vac power supply are also available for the serial adapter. For reasons of EMI compatibility, a 3VA transformer (TRF in fig. 3.4.2.1) (see options) is required for each PJ32 instrument with 12Vac power supply.

3.2.4 Electrical connections, PJ32

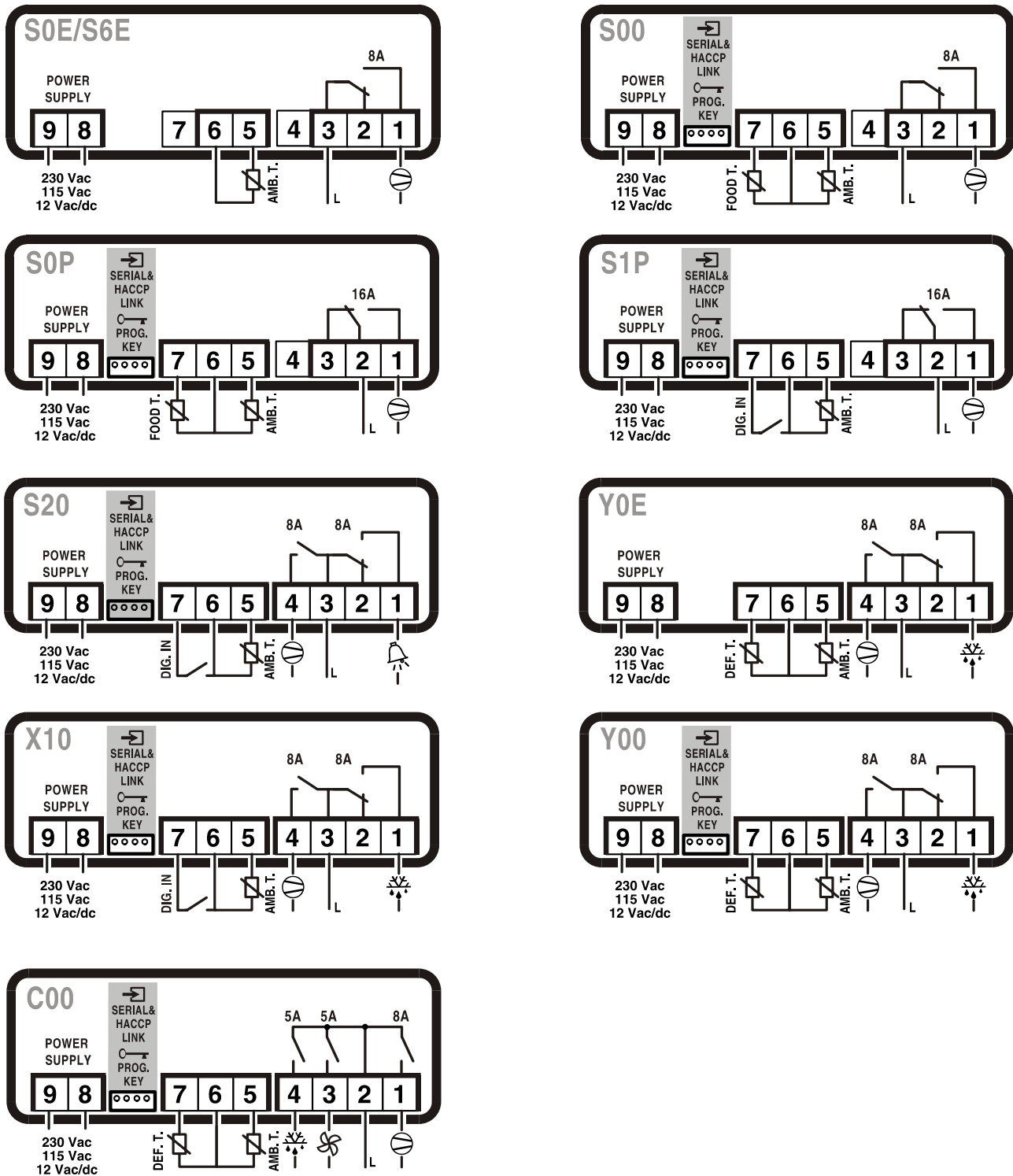

Fig. 3.2.5.1

Warnings:

- before connecting the power, check the correct value of the power supply as shown on the label of the instrument;
- all models use NTC probes, except for the PJ32S6E0*, which uses PTC probes;
- for models S200 and S201 the alarm relay can be set as normally energised or normally de-energised, using parameter **H1**.

3.3 Setting the main operating parameters

The plug-in series instruments are supplied ready to use. They are in fact programmed in the factory (default settings) to respond to the more common requirements. The programming is performed by assigning all the parameters the more frequently required value; the table below lists the parameters and the corresponding default value.

code	description	type	d min	d max	default	unit of measure (**)
/C	ambient probe calibration	F	-127	127	0	°C/°F x 0,1
/2	measurement stability (probe delay and range limit), 1 = fast	C	1	15	4	
/4	selection of probe to display (0 = ambient, 1 = defrost)	C	0	1	0	
/5	selection °C/°F (0=°C)	C	0	1	0	
rd	control differential (hysteresis)	F	0	19	2	°C/°F
r1	minimum set allowed to the user	C	-50	127	-50	°C/°F
r2	maximum set allowed to the user	C	-50	127	60	°C/°F
r3	enable alarm Ed (1=enable)	C	0	1	0	
r4	set automatic variation of the Set point for night operation	C	-20	20	3	°C/°F
c0	compressor start delay at instrument on	C	0	15	0	min
c1	minimum time between 2 successive starts of the compressor	C	0	15	0	min
c2	minimum compressor off time	C	0	15	0	min
c3	minimum compressor on time	C	0	15	0	min
c4	Duty Cycle safety relay ON time	C	0	100	0	min
cc	continuous cycle duration	C	0	15	4	hours
c6	alarm bypass time after continuous cycle	C	0	15	2	hours
d0	type of defrost (0=heat el., 1=gas, 2=heat. el. time, 3=gas time)	C	0	3	0	
dI	interval between two defrosts	F	0	199	8	hours/min
dt	end defrost temperature	F	-50	127	4	°C/°F
dP	maximum defrost duration or effective duration for d0=2 or d0=3	F	1	199	30	min/s
d4	defrosting at instrument on (1=yes)	C	0	1	0	
d5	defrost delay	C	0	199	0	min
d6	display off during defrost (1=yes)	C	0	1	1	
dd	post-defrost dripping time	F	0	15	2	min
d8	alarm bypass time after defrosting	F	0	15	1	hours
d9	defrost priority over minimum compressor times (1=yes)	C	0	1	0	
dC	time basis (0 =hours/min, 1=min/s)	C	0	1	0	
A0	alarm/fan differential	C	0	19	0	°C/°F
AL	shift low temperature alarm threshold	F	0	127	0	°C/°F
AH	shift high temperature alarm threshold	F	0	127	0	°C/°F
Ad	temperature alarm delay	C	0	199	0	min
A4	digital input configuration	C	0	4	0	
A7	alarm input detection delay	C	0	199	0	min
F0	fan operating mode	C	0	1	1	
F1	fan on temperature	F	-50	127	5	°C/°F
F2	fans off with compressor off (1=yes)	C	0	1	1	
F3	fans off during defrost (1=yes)	C	0	1	1	
Fd	fan time-out during post dripping	F	0	15	1	min
H0	serial address	C	0	199	1	
H1	IR34S: enable defrosting, IR34C: multifunction relay function	C	0	1	1	
H2	disable keypad, 0=disabled	C	0	1	1	
H4	disable buzzer	C	0	1	0	
L1	control set point	S	-50	127	4	°C/°F

Tab. 3.3.1

(**) **unit of measure** (hereafter **u. of m.** in the tables).

To achieve the maximum performance from the controls, or in the case of special needs, the values of the operating parameters can be modified. The following notes describe the factory settings and the parameters which are more frequently modified (set point, differential, etc.). Furthermore, for convenience, all parameters which should be checked before operating the unit are indicated.

Based on the factory settings, the **main** functions are the following:

- **PJ32S**: configured as a thermostat, with operation in degrees centigrade, **set point** at 4°C and differential of 2°C. The DEFROST operation is enabled by time at 8 hour cycles lasting 30 minutes (compressor stop only). The high and low temperature alarms are disabled. In the case of operation in continuous cycle, the duration is 4 hours and the temperature alarm is bypassed for 2 hours from the end of the cycle.
- **PJ32Y, PJ32X**: have the same settings as the PJ32S. Furthermore, these are programmed to manage defrosting using electrical elements, with operation based on time for the X version, and with the second probe for the Y model. The display of the temperature during defrosting remains on the last value acquired before the start of the defrost. There is an evaporator dripping time of two minutes after the defrost, and the high temperature alarm is bypassed for one hour from end defrost.
- **PJ32C**: on top of the functions of the IR32Y, these units are set to manage the evaporator fans, which are stopped when the compressor is off and during defrosting. Furthermore, a one minute pause is set for the fans after dripping, to allow the evaporator to return to operating temperature before starting forced ventilation. In the IR32C, the defrost is stopped when the probe on the evaporator measures 4°C (defrost by temperature).

If many of the instrument's parameters need to be modified during installation, it may be useful to set the complete configuration of one instrument, and then copy it using the KEY accessory; in this case the operation can be performed in just a few seconds, with a complete copy of all the parameters.

3.4 Table summarising the parameters to be checked before installation

	code	parameter	type	min	max	uom	def
control parameters	rd	control differential	F	0	+19	°C/°F	2
	L1	control set point		-50	127	°C+/°F	4
defrost parameters	d0	type of defrost (0=heating element, 1=hot gas, 2=heating element by time, 3=hot gas by time)	C	0	1	flag	0 (*)
	dI	interval between defrosts	F	0	199	h	8
	dt	end defrost temperature set point	F	-50	+127	°C/°F	4
alarm parameters	Ad	temperature alarm delay	F	0	+199	min	0
	AL	shift low temperature alarm threshold	F	0	+127	°C/°F	0
	AH	shift high temperature alarm threshold	F	0	+127	°C/°F	0
other settings	H1	enable defrosting mod. S and selection of multifunction relay function (alarm)	C	0	1	flag	1

Tab. 3.4.1

(*) **WARNINGS:**

- for all models where the second probe is not used or used for the display of the product temperature, or for the models with the alarm relay, parameter **d0** must be set for timed defrost, in this way, any alarms from the second probe are not signalled. To stop the running of the defrost cycles, parameter **dI** must also be set to 0;
- the S models with two probes (codes PJ32S00 and S0P) have been designed to use the second probe for measuring and displaying the food storage temperature (Food Probe). To manage the second probe, these models are in fact programmed as Y models, with all the corresponding parameters, but do not have the defrost relay; it is clear that they must be set so as defrosting is not enabled, or, if necessary, only timed defrost with compressor off;
- the S models with alarm relay, PJ32S20*, to use the function of programming the status of the alarm relay by parameter **H1** are set as X models; as they don't have the defrost relay they must be programmed so as defrosting is not enabled, or, if necessary, only timed defrost with compressor off (**dI**=0 or **dI**>0 for cyclical defrost).

4. PARAMETERS - DESCRIPTION

4.1 The configuration parameters

The parameters can be classified in two groups for setting:

- frequent parameters (indicated by type F in the following tables);
- configuration parameters (type C), whose selection is 'password' protected to prevent unwanted tampering.

The assigning of the parameters to groups F and C can also be programmed, but only via serial access using the key or a supervisory system.

Following is a description of each parameter, indicating the versions it is available in and the possible values.

Furthermore, the **default value** (def.) is listed, that is the value assigned to the parameter in the factory.

4.2 Classification of the parameters

The parameters, as well as being divided by type, are also grouped in logical categories identified by the first letters of the parameters themselves. Following is a list of the existing categories, with the meaning and identifying letters.

PS	indicates the password, this must be entered to access the configuration parameters (C)
category	description
/	temperature probe management parameters
r	temperature control parameters
C	compressor management parameters
d	defrost management parameters
A	alarm management parameters
F	evaporator fan management parameters
H	general configuration parameters

Tab. 4.2.1

4.3 The password PS

This is deliberately included to complicate access to type C parameters, so as to prevent accidental or unauthorised modifications. Type C parameters are in fact those which modify the configuration of the control. Once entered into the configuration parameters section using the password, the control also allows, for convenience, type F parameters to be modified.

When displaying the type F parameters, type C parameters are accessed as follows:

1. select the password parameter **PS**;
2. enter and confirm the value 22, the correct password;
3. all the parameters, F and C, can now be selected on the display.

4.4 / = temperature probe management parameters

	probe parameters	type	min	max	uom	def
/C	ambient probe calibration x10 (tenths of a degree)	F	-127	+127	°C/°F	0.0
/2	measurement stability	C	1	15	-	4
/4	display control / food storage probe	F	0	1	-	0
/5	display in °C/°F (0=°C, 1=°F)	C	0	1	flag	0

Tab. 4.4.1

/C: calibration or Offset

This parameter allows the temperature shown on the display to be corrected. The value assigned to this parameter is in fact added to (positive value) or subtracted from (negative value) the temperature measured by the probe. For example, if the temperature displayed needs to be decreased by 2.3 degrees, set /C=-23.

The Offset can range from -127 to +127, with a variation in the reading between -12.7 and +12.7 (°C/°F). The parameter does not act on the defrost probe (in all the models with two probes). Def.: 0.0 (no Offset to probe reading).

Available on all models.

/2: measurement stability

Defines the coefficient used to establish the temperature measurement. Low values assigned to this parameter offer the prompt response of the sensor to variations in temperature; the reading is however more sensitive to disturbance. High values slow down the response but guarantee greater immunity to disturbance, that is a more stable and more precise reading. The setting is also used also for the second probe, if present. Value from 1 to 15. Def.: 4.

Available on all models.

/4: display control or food storage probe

For instruments with two probes (S, Y, C), this parameter selects whether to display the temperature of the control probe (ambient probe) or the second probe, which in this case is used only to display the temperature of the food. The use of the second probe for this purpose means that it can no longer be used to control defrosting; the corresponding parameters must be modified as a consequence. The parameter /4 only selects the value to be displayed, all the other display and control modes remain unchanged.

In the versions with just one probe (ambient), the parameter, when present, must always be zero (0). Def.: 0, display ambient probe. Available on models Y, C and S with two probes.

Warning: the S models with two probes have been designed only to use the second probe for the measurement and display of the food storage temperature (Food Probe). To manage the second probe, these models are in fact programmed as Y models, with all the corresponding parameters; it is clear that they must be set so as defrosting is not enabled, or, if necessary, only timed defrost (**d0**=2, **dI**=0, **dt**=-50), furthermore, if the second probe is not used, it must be disabled (/4=0 and **d0**=2), to avoid the signal **E1** (probe alarm).

/5: °C or °F selection

Defines the unit of measure used for the control and the display.

0 = degrees centigrade, 1 = degrees Fahrenheit.

Warning: when changing from one unit of measure to the other, all the values of the temperature parameters must be modified in the new unit of measure.

Def.=0, operation in degrees centigrade. Available on all models.

4.5 r = temperature control parameters

	control parameters	type	min	max	uom	def
rd	control differential (0= 0.5 °C)	F	0	+19	°C/°F	2
r1	minimum set allowed	C	-50	r2	°C/°F	-50
r2	maximum set allowed	C	r1	+127	°C/°F	60
r3	enable alarm ED for models Y, X, C	C	0	1	flag	0

Tab. 4.4.1

rd: control delta

Sets the value of the differential, or hysteresis, used in the temperature control. A narrow, that is numerically small differential, guarantees an ambient temperature which stays close to the **set point**, yet with frequent activation and deactivation of the main actuator (normally the compressor). The life of the compressor can still be protected by suitably setting the parameters which limit the number of activations per hour and the minimum off time (see C parameters).

In all the refrigeration instruments the differential is set to the right of the **set point**, as indicated in the figure (DIRECT operation):

direct (cooling)

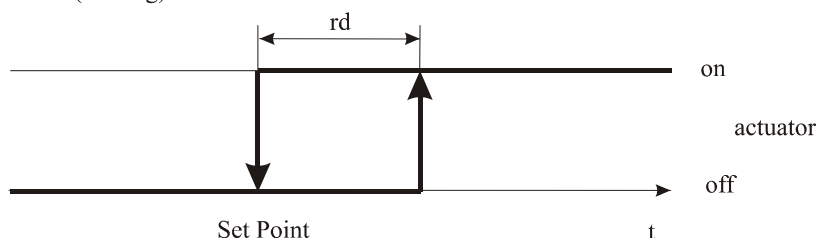

Fig. 4.5.1

Def.: **rd**=2

Available on all models

r1: minimum SET allowed

Determines the minimum value which can be set for the set point. This parameter prevents the user from setting the set point lower than the value indicated by **r1**. Def.: -50

r2: maximum SET allowed

Determines the maximum value which can be set for the set point. This parameter prevents the user from setting the set point higher than the value indicated by **r2**. Def.: +60

r3: enable alarm ED

For models Y, X, C. With **r3=1**, the alarm is enabled and indicates end defrost due to the maximum time being reached.

Warning: for the model S with defrosting enabled (**H1=1**), the alarm is not present in that the operation is by time only with compressor off. If required, the value set via the serial connection must be 0.

Def.: 0 alarm ED inhibited.

4.6 c = compressor management parameters

	compressor parameters	type	min	max	uom	def
C0	compressor start delay at instrument on	C	0	15	min	0
C1	minimum time between 2 successive starts of the compressor	C	0	15	min	0
C2	minimum compressor off time	C	0	15	min	0
C3	minimum compressor on time	C	0	15	min	0
C4	duty setting (compressor safety, 0=OFF,100=ON)	C	0	100	min	0
Cc	continuous cycle duration	C	0	15	hours	4
C6	alarm bypass after continuous cycle	C	0	15	hours	2

Tab. 4.6.1

c0: start delay of the compressor and the fans (if managed) at instrument on

At the moment the control is turned on, the start-up of the compressor and evaporator fans is delayed by a time (minutes) equal to the value assigned to this parameter. This delay allows the compressor to be protected against repeated starts in the case of frequent voltage drops or power failures. For example, setting **c0=6** forces the compressor to wait 6 minutes before starting from when the power returns. In the case of systems with more than one compressor, parameter C0 can also be used to avoid simultaneous start-ups of the units, simply by setting each compressor a different value for C0.

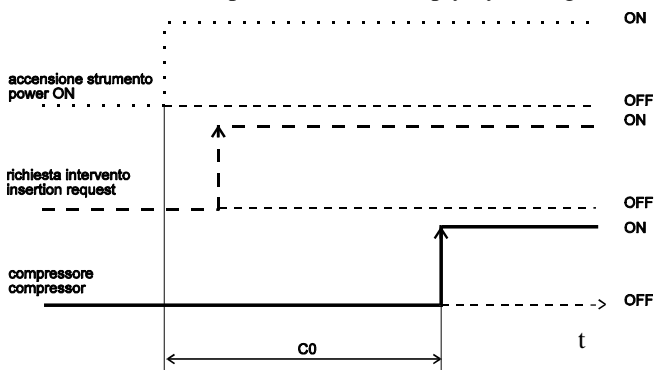

Def.: **c0=0** (no minimum delay for the activation of the compressor when the instrument is turned on).
Available on all models

Fig. 4.6.1

c1: minimum time between 2 successive starts of the compressor

Sets the minimum time (in minutes) that must elapse between two start-ups of the compressor, irrespective of the temperature and the set point. Setting this parameter can limit the number of activations per hour. For example, if the maximum number of activations allowed per hour is 10, simply set **c1=6** to ensure this limit is respected.

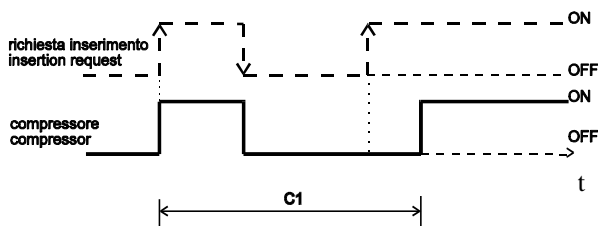

Def.: **c1=0** (no minimum time between two activations).
Available on all models.

Fig. 4.6.2

C2: MINIMUM COMPRESSOR OFF TIME

Sets the minimum time, in minutes, that the compressor stays off. The compressor is not re-started until the minimum time selected (**c2**) has passed since the last shut-down. This parameter is useful in ensuring pressure equalisation after the shut-down, in the case of systems with hermetic and scroll compressors.

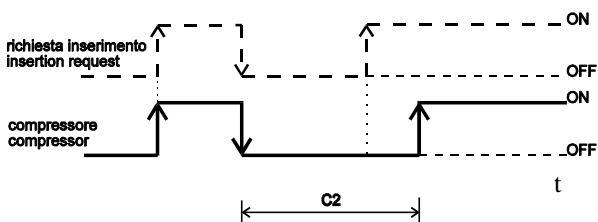

Def.: **c2=0** (no minimum OFF delay time).
Available on all models.

Fig. 4.6.3

c3: minimum compressor on time

Sets the minimum time the compressor stays on. The compressor is not shut-down unless it has been on for the minimum time selected.

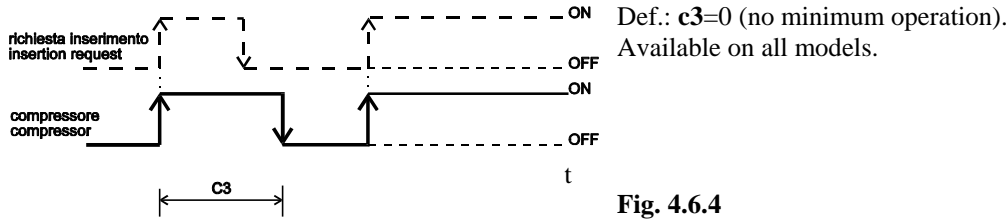

Fig. 4.6.4

c4: duty setting or safety probe

In the event of the **control probe fault** alarm (that is the ambient probe is short-circuited or disconnected) this parameter ensures the operation of the compressor until the fault is resolved. In practice, the compressor, not being able to be activated according to temperature (due to the probe fault), works cyclically with an ON time equal to the value assigned to parameter **c4** (in minutes) and a fixed OFF time of 15 minutes. There are two values for **c4** which create special conditions.

If **c4** = 0, in the event of an ambient probe fault, the compressor will be **always off**;

if **c4** = 100, the compressor will remain **always on**; and the 15 minute off time is not considered.

- For other values of **C4**, at the moment a probe error (**E0**) is detected, the duty setting cycle starts from the current status of the compressor:

1. if ON, it remains ON for the set time (**C4**), considering the time it has already been ON;
2. if OFF, it remains OFF for the OFF time, again considering the time it has already been OFF.

The time settings for compressor C1, C2, C3 are in any case always respected.

- If the control probe error occurs when the control is defrost mode or continuous cycle, the control instantly exits this status and activates duty setting. To re-activate the defrost or continuous cycle operation, the ambient probe must be reset.

Remember that in the event of ambient probe errors, manual defrosts can not be performed.

If the probe error is no longer present, the machine returns to normal operation. The compressor again takes on the logic of the control, respecting the times C1, C2, C3.

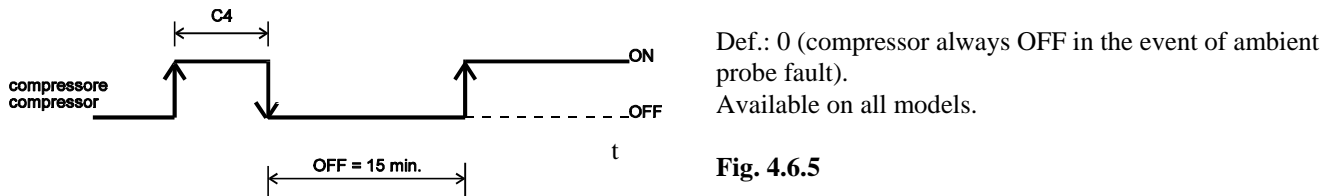

Fig. 4.6.5

cc: continuous cycle duration

This is the time in hours that the compressor stays continuously on in order to lower the temperature to the set point. This function is used when rapid product temperature drops are required, for example, after loading the store; in this phase the temperature can fall below the set point by the value set using parameter **AH**. If **cc**=0, continuous cycle is not enabled. The control exits the continuous cycle procedure after the time set for the parameter **cc** or when the minimum temperature has been reached (see **minimum temperature alarm**, parameter **AL**).

Def.: 4 (hours). Available on all models .

c6: alarm bypass after continuous cycle

This is the time, in hours, that the temperature alarm is disabled after a continuous cycle. In practice, if the temperature of the refrigeration unit, after the continuous cycle, falls due to inertia below the minimum temperature level (set point - **AL**) the activation of the low temperature alarm is delayed for a time equal to **c6**. Remember that at the minimum temperature (set point - **AL**) the continuous cycle is forced off.

Def.: 2 (hours). Available on all models.

4.7 d = defrost management parameters

	defrost parameters	type	min	max	uom	def
d0	type of defrost (0=heat. element, 1=hot gas, 2=heat elem. by time, 3=hot gas by time)	C	0	3	flag	0
dI	interval between defrosts	F	0	199	hours	8
dt	end defrost temperature set point	F	-50	+127	°C/°F	4
dP	maximum defrost duration	F	1	199	min	30
d4	defrost at instrument on (0=no, 1=yes)	C	0	1	flag	0
d5	defrost delay at instrument on or from multifunction input	C	0	199	min	0
d6	display off during defrosting (0=no, 1=yes)	C	0	1	flag	1
dd	dripping time	F	0	15	min	2
d8	alarm bypass time after defrosting and/or door open	F	0	15	hours	1
d9	defrost priority over compressor protection (0=no, 1=yes)	C	0	1	flag	0
d/	defrost probe reading	F	-	-	°C/°F	-

Tab. 4.6.1

d0: type of defrost

Sets the type of defrost for the instruments fitted with defrost relay:

d0	type of defrost
0	heating element
1	hot gas
2	heat. element by time
3	hot gas by time

Tab. 4.7.2

Def.: **d0**=0, defrost using heating element. Available on models Y, X and C.

Warning: for the S models with two probes or with alarm relay, a time must be set (recommended **d0**=2).

dI: interval between defrosts

The defrost is performed periodically at an interval equal to the value of **dI** (in hours or minutes, see parameter **dC**). The interval **dI** starts to be counted from the previous defrost beginning. If the time is equal to 0 (**dI**=0), the defrost is not performed, except when forced from the keypad or digital input. During defrosts the temperature alarms are inhibited.

Warnings: possible errors in measuring the times must be taken into account, typically $\pm 5\%$ and maximum $\pm 10\%$.

Def.: 8 hours - Available on all models.

For the S models with two probes or with alarm relay, this must be set to zero to exclude cyclical defrosts.

dt: end defrost temperature set point

For units fitted with end defrost probe (Y and C), this parameter allows an evaporator temperature to be set at which the defrost is stopped (the evaporator temperature is measured by the defrost probe). If, at the start of a defrost cycle, the temperature measured by the defrost probe is greater than the set end defrost value, the cycle is not performed. In the event of defrost probe failure, the control performs a timed defrost with a duration equal to the value set for **dP**. The same is true if the end defrost set point can not be reached, the defrost is stopped after a maximum time equal to the value, in minutes, of **dP**, and the error **Ed** is displayed (if enabled by **r3**) and stays on until a correct defrost cycle is performed, that is one which ends by temperature. Def.: 4 °C - Available on models Y and C.

dP: maximum defrost duration

Determines the duration of the defrost in minutes (or seconds, see parameter **dC**). For instruments without evaporator probe (S with **H1**=1 and X) this parameter represents the effective duration of the defrost.

Def.: 30 min. Available on all models.

d4: defrost at instrument on

Activates a defrost cycle when the instrument is turned on. The request for defrost when the unit is turned on has priority over the activation of the compressor and the activation of the continuous cycle.

The possible values are:

0 = no, no defrost is performed when the instrument is turned on;

1 = yes, a defrost cycle is performed when the instrument is turned on.

Forcing a defrost cycle when the instrument is turned on may be useful in special situations, e.g. if the system is subject to frequent voltage drops. In fact, in the event of power failures the instrument's internal clock, which calculates the interval between two defrosts, starting from zero, is reset. If the frequency of the voltage drop were, in an extreme case, greater than the defrost frequency (e.g. a voltage drop every 8 hours against a defrost every 10 hours), the control would never perform a defrost. In this type of situation it is better to activate the defrost when the unit is turned on, above all if the defrost is controlled by temperature (probe on the evaporator), so unnecessary defrosts are avoided or at least reduced in time. In the case of systems with many units, if defrost on start-up is selected, after a voltage drop all the units will start a defrost. This may cause overloads. To avoid this, parameter **d5** can be exploited, which allows a delay to be set before the defrost starts, a delay which obviously must be different for each unit.

Def.: **d4**=0, the instrument does not perform a defrost when the unit is turned on. Available on all models.

d5: defrost delay at instrument on or from multifunction input

Represents the time which must elapse between when the control is turned on and the start of the defrost.

In the case where the digital input is used to enable the defrost (see parameter **A4**=2) or to start a defrost from an external contact (see parameter **A4**=3), this parameter represents the delay between the enabling of the defrost, or its request, and the effective start of the cycle. The defrost from digital input (see parameter **A4**) can be exploited to perform defrosts in real time. Simply connect a timer to the multifunction digital input (again see parameter **A4**). The defrost will be activated when the timer contact is closed. In the case where more than unit is connected to the same timer, it is recommended to set parameter **d5** to delay the defrosts to a different time for each unit. Furthermore, to avoid unnecessary defrosts controlled by the instrument's internal clock, it is suggested to set parameter **dI**=0 (only manual defrosts from the keypad or multifunction contact) or to set **dI** to a value which is greater than the maximum set interval, allowing operation with safety defrosts in respect to the external timer.

Def.: **d5**=0 (no delay in the start of the defrost from when the instrument is turned on or from the activation of the multifunction input)

Available on all models.

d6: display off during defrost

Blocks the display of the ambient temperature during the defrost cycle at the last value read before the current defrost.

The display normally returns when the measurement first reaches the set point or, in any case, after the set alarm bypass time after defrost (parameter **d8**).

If the display during defrost is enabled, the instrument displays alternatively the message **dF** and the value read by the control probe. This warns that possible high temperatures are due to defrost in progress. The off mode is also valid for the display of the second probe (Par. /4), if enabled.

Def.: **d6**=1 (during defrost the last temperature measured before the start remains on the display). Available on all models.

dd: dripping time

This parameter forces the compressor and the evaporator fans off after a defrost, in order to allow the evaporator to drip.

The value of this parameter indicates the minutes of rest, if **dd** = 0 no dripping is set, therefore at end defrost the compressor starts immediately.

Def.: **dd**=2 min. Available on all models.

d8: alarm bypass time after defrost

Indicates the time the high temperature alarm is bypassed from the end of the defrost

Def.: **d8**=1 bypass time. Available on all models.

d9: defrost priority over compressor protection

Overrides the compressor protection times (**c1**: minimum time between 2 successive starts, **c2**: minimum off time and **c3**: minimum on time) at the start of the defrost. The possible values are:

0 = the protection times are respected;

1 = the protection times are overridden; the defrost has priority and does not respect the compressor time settings.

It is useful, for example, with hot gas defrost to avoid delaying the defrost in the case where the compressor has just stopped and there is a minimum time between two starts. **Remember, however, that in this case the maximum number of activations per hour of the compressor may not be respected.**

Def.: **d9**=0 the defrost respects the compressor time settings (as default these are set to zero). For instruments with a serial number less than 5000 **d9**=1 by default. Available on all models.

d/: defrost probe reading

Selecting this parameter displays the value read by the defrost probe for instruments where fitted. Once the parameter **d/** has been selected, the value of the temperature measured by the defrost probe can not be modified but only read. Available on models Y and C.

dC: time basis

Modifies the unit of measure used to count the times for parameters **dI** (defrost interval) and **dP** (defrost duration). The possible values are:

0 = **dI** expressed in hours and **dP** in minutes;

1 = **dI** expressed in minutes and **dP** in seconds.

Parameter **dC**=1 can be useful to test the operation of the defrost function with reduced times. **Remember, however, that if the defrost requires the compressor to be on (hot gas defrost) and parameter d9=1, the compressor risks being damaged due to an excess of start-ups in a short time.**

Parameter **dC**=1 is on the other hand very useful in the event where versions Y and X need to be used to manage air driers. The defrost cycle thus becomes the condensation discharge cycle, which must occur at close intervals (minutes) and for very brief durations (seconds).

Def.: **dC**=0, that is **dI**, defrost interval, in hours and **dP**, maximum defrost duration, in minutes. Available on all models.

4.8 A = alarm management parameters

alarm parameters		type	min	max	uom	def
A0	alarm and fan differential (0= 0.5 °C / °F)	C	0	+19	°C/°F	0
AL	low temperature alarm (difference from set)	F	0	+127	°C/°F	0
AH	high temperature alarm (difference from set)	F	0	+127	°C/°F	0
Ad	temperature alarm delay	C	0	199	min	120
A4	multifunction input configuration	C	0	4	-	0
A7	external alarm detection delay (A4 =1, Multifunct. Input)	C	0	199	min	0

Tab. 4.8.1

A0: alarm and fan differential

Represents the differential used to activate the high and low temperature alarms (**AL** and **AH**) (see figure below) and fan management (see parameters **F**). In the case of an alarm, as seen in the figure, the value of **A0** determines the actual activation of the temperature alarms.

Def.: 0 °C (equal to 0.5 °C). Available on all models.

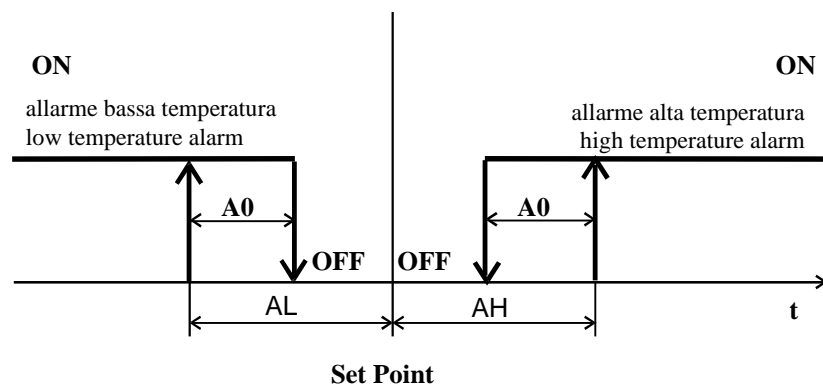

Fig. 4.8.1

AL: minimum temperature alarm

Selects the low temperature alarm. The value of **AL** does not indicate the alarm temperature but rather the **maximum difference allowed below the set point**.

For **all models**:

$$\text{low temperature alarm} = (\text{set point}) - (\text{value of AL})$$

Note that changing the set point automatically changes the low temperature alarm, in that maximum difference allowed remains the same (=AL). The low temperature alarm has an automatic reset. This means that if the temperature returns above the threshold value +A0, the alarm signal automatically stops. Finally, please remember that the low temperature alarm is also used in the continuous cycle (see corresponding section on page 59). In fact, if the temperature falls to the alarm level the continuous cycle is automatically deactivated, even if the selected period has not elapsed. The deactivation does not give rise to an alarm signal.

Def.: **AL=0** (low temperature alarm inhibited). Available on all models.

AH: high temperature alarm

Selects the high temperature alarm. The value of **AH** not indicates the temperature of alarm but rather the **maximum difference allowed above the set point** (working point).

Per **all models**:

$$\text{high temperature alarm} = (\text{set point}) + (\text{value of AH})$$

Note that changing the set point automatically changes the high temperature alarm, in that maximum difference allowed remains the same (AH). The high temperature alarm also has an automatic reset. When the temperature falls below the threshold value – A0 the alarm signal automatically stops.

Def.: **AH=0** (high temperature alarm inhibited). Available on all models.

Ad: temperature alarm delay

Indicates after how many minutes the temperature alarm is signalled from when it is detected. If the temperature, after the delay **Ad**, is back within the allowed limits, the alarm is not signalled.

Setting a delay to signal of the temperature alarms may help eliminate false alarms due to interference on the probe signal or situations lasting a short time (for example, opening the cold room door briefly).

The temperature alarm delay has no effect on two special functions: defrost and continuous cycle. To delay any temperature alarms **after** these functions, parameter **d8** for defrost and **c6** for continuous cycle must be modified. Remember that during defrost and continuous cycle no temperature alarms are generated.

Def.: **Ad=0** (instant temperature alarm). Available on all models.

A4: Multifunction digital input configuration

The MULTIFUNCTION digital input can assume different meanings according to the value attributed to this parameter, and according to the model of control used. Following is a description of the possible functions:

A4 = 0: input not active

The Multifunction digital input is not used. This is the default value for all versions.

A4 = 1: external alarm

An external alarm requiring immediate intervention can be connected to the digital input (for example, high pressure or compressor thermal overload alarm). In particular, the alarm is detected when the contact opens (normal operation with contact closed). The management of the alarm can be instant, or with a delay according to the value of parameter **A7** (0 = instant).

The activation of the alarm brings a message on the display (see alarm **IA**), activates the buzzer, if featured, and causes the following actions on the actuators:

- compressor** causes the compressor to shut-down from external alarm (immediate if **A7=0**)
- fans** causes operation according to the fan parameters (**F**). If the external alarm is detected during a defrost or a continuous cycle, the control exits the procedure

When **the alarm stops**, the machine returns to operation as follows:

- DEFROST** defrosts can again be performed. The next starts after the set time **dI** (interval between defrosts)
- compressor** if at the instant the alarm ends the compressor is on, it stays on for the minimum set time (parameter **c2**). If it is off, it stays off for a minimum time equal to the minimum off time (parameter **c3**)

The configuration with delay (**A7 > 0**) is especially useful for managing the low pressure alarm. It is frequent, in fact, for the unit to detect a low pressure alarm when first turned on, due to the environmental conditions and not a unit malfunction. Setting an alarm delay avoids false signals. In fact, by carefully calculating the delay, if low pressure is due to environment conditions (low temperature) the alarm will automatically return before the set delay elapses. The effect on the compressor, fans, defrost and continuous cycle are the same, after the set delay, as above.

Warning: as already indicated in the installation instructions, to ensure the safety of the unit in the event of serious alarms (for example, the pressure alarms), the unit must be fitted with all the electromechanical devices required to guarantee correct

operation according to the standards in force. The electronic control on its own can not be used to guarantee safety in the event of serious alarms.

For all models, including S with H1=1:

A4 = 2: enable defrost

An external contact can be connected to the multifunction input to enable or inhibit the defrost function. When the contact is open, the defrost is inhibited, while it is enabled when the contact is closed. If the contact is closed and there is no request from the controller, obviously the defrost is not performed. If the contact is closed and a defrost is in progress, opening the digital input immediately stops the defrost and the unit returns to the normal operation (without performing the dripping phase). Upon request for a defrost the corresponding defrost LED starts to flash, until the next enabling action (closing of the contact). This function is useful, for example, in the case of multiplexed showcases with hot gas defrost. These systems must be defrosted by island and thus, at any one moment, some islands are enabled for defrost, while others are inhibited. Another use of the function is to prevent defrosting the units available to the public during opening hours. Any defrost requests when the contact is open will stay on hold until the closing of the contact.

A4 = 3: start defrost from external contact

This function allows the defrost to be started from an external contact. If the defrost is started using an external contact, all the type 'd' parameters selected are valid. In particular, it may be useful to set **dI**=0 to enable manual defrosts or defrosts from external contact only, excluding defrosts generated by the internal clock.

This function is useful in the case where **real time defrosts** are required. To perform these, simply connect a mechanical or electronic timer to the digital input. When the contact of the timer moves from open to closed it enables the defrost request. It may be the case, as mentioned in the description of parameter **d5**, that more than one unit is connected to the same timer. Selecting a different value for **d5** for each unit will avoid simultaneous defrosts.

Warning: the minimum duration must be 0.5 seconds.

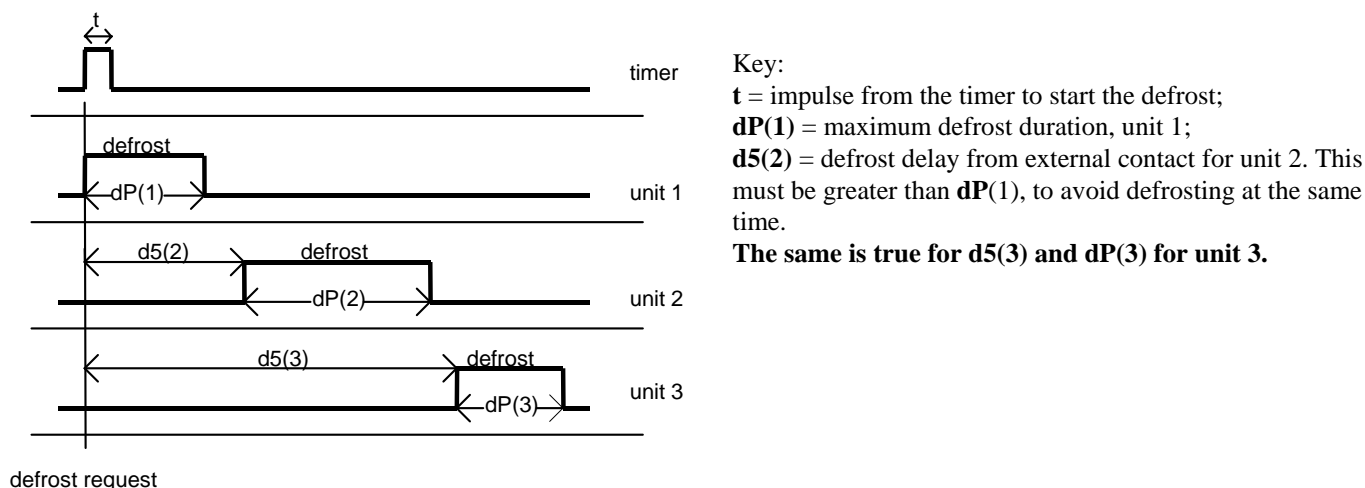

Fig. 4.8.2

A4 = 4: curtain switch / night-time operation

Setting parameter **A4**=4 manages the contact which signals the closing of the curtain on showcases or modifies the set point for night-time operation. With the contact closed the set point is modified by the value **r4** (set point variation for night-time operation).

The following table summarises the functions assumed by the multifunction digital input, according the setting of **A4**.

value parameter A4	meaning	S	Y	X	C
0	input not active	◆	◆	◆	◆
1	external alarm instant or delayed (A7)	◆	-	◆	-
2	enable defrost (closed = enabled)	◆	-	◆	-
3	start defrost on closing	◆	-	◆	-
4	curtain switch or night-time operation	◆	-	◆	-

Tab. 4.8.2

Warning: parameter **A4** is accessible on all models, but can only be used on those which effectively have the input, in alternative to the second probe. When the input is not present, the value of **A4** must be zero (0), indicated by the - (dash) in Tab. 4.8.2.

A7: external alarm detection delay (multifunction input)

Sets the delay (in minutes) for detecting the external alarm when **A4**=1.

Def.: **A7**=0. Available on all models.

4.9 F = evaporator fan management parameters

	alarm parameters	type	min	max	uom	def
F0	fans subject to the fan controller (0=no, 1=yes)	C	0	1	flag	0
F1	fan shut-down temperature (effective temperature °C - °F)	F	-50	+127	°C/°F	5
F2	stop fan when compressor off (0=no, 1=yes)	C	0	1	flag	1
F3	stop fans for defrost (0=no, 1=yes)	C	0	1	flag	1
Fd	post dripping off	F	0	15	min	1

Tab. 4.9.1

F0: fans subject to the fan controller

The fans can be subject to the fan controller, which manages them according to the temperature measured by the defrost probe. Alternatively, the fans are always on during a defrost (see parameter **F3**), with the possibility of switching them off when the compressor is off (see parameter **F2**), during the dripping period (see parameter **dd**) and for a further post dripping period (see parameter **Fd**). The values allowed for this parameter are:

F0=0 (=no). In this case the fans are not subject to the fan controller, and are always on, except for the limits set by **F2**, **F3**, **Fd** and, if necessary, by **dd**.

F0=1 (=yes). The fans are subject to the fan controller (see parameter **F1**) and parameters **F3** and **Fd**, which have priority over the controller.

Remember that if there is a dripping period (parameter **dd**), the fans are off in any case.

Def.: **F0**=0, not subject to the fan controller. Available on PJ32C.

F1: fan shut-down temperature (parameter operative only if F0=1).

The controller activates the fans only when the temperature of the evaporator is lower than the value set for **F1**. **F1 is the effective (real) temperature and not the difference from the set point**. Once off, the fans start again when the difference between the probe and the set point is equal to **+A0**, where **A0** is the fan control differential (see the figure below).

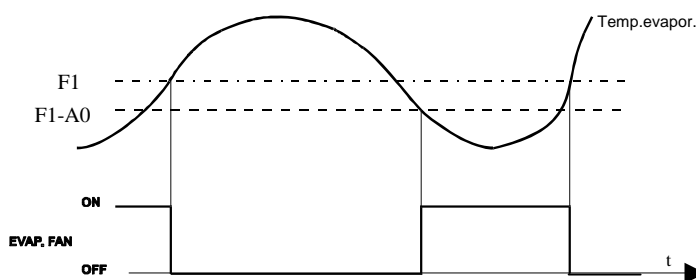

Fig. 4.9.1

Def.: **F1**=5, as shown in the figure, the fans stay on until the evaporator temperature is less than 5°C. Available on PJ32C.

F2: stop fans with compressor off

Decides if the fans must be always on (excluding **F3**, **dd** and **Fd**) or only when the compressor is on.

F2=0 (= no): The fans are also on when the compressor is off

F2=1 (= yes): The fans are off when the compressor is off.

Def.: **F2**=1, fans off when the compressor is off. Available on PJ32C.

F3: stop fans for defrost

Decides if the fans must operate or not during defrost.

F3=0 (= no): the fans operate during the defrost.

F3=1 (= yes): the fans do not operate during the defrost.

Remember that during the dripping time, if featured, the fans are always off.

Def.: **F3**=1, evaporator fans off during defrost. Available on PJ32C.

Fd: post dripping off (active both when F0=0 and F0=1)

The fans, after the defrost, can be stopped for a further period (in minutes) defined by the value of **Fd**. This is useful to allow the evaporator to return to operating temperature after the defrost, thus avoiding forcing 'hot' air into the refrigerator. In the case of management by fan controller, the time **Fd** does not need to be selected, in that the controller makes the fans start again when the evaporator reaches operating temperature. If the fan controller is active (**F0=1**), assigning **Fd** a value other than zero means the fans **stay off** for a time equal to the value of **Fd**, irrespective of the temperature of the evaporator.

Def.: **Fd**= 1 minute post-dripping stop. Available on: PJ32C.

Diagram summarising operation of the evaporator fans

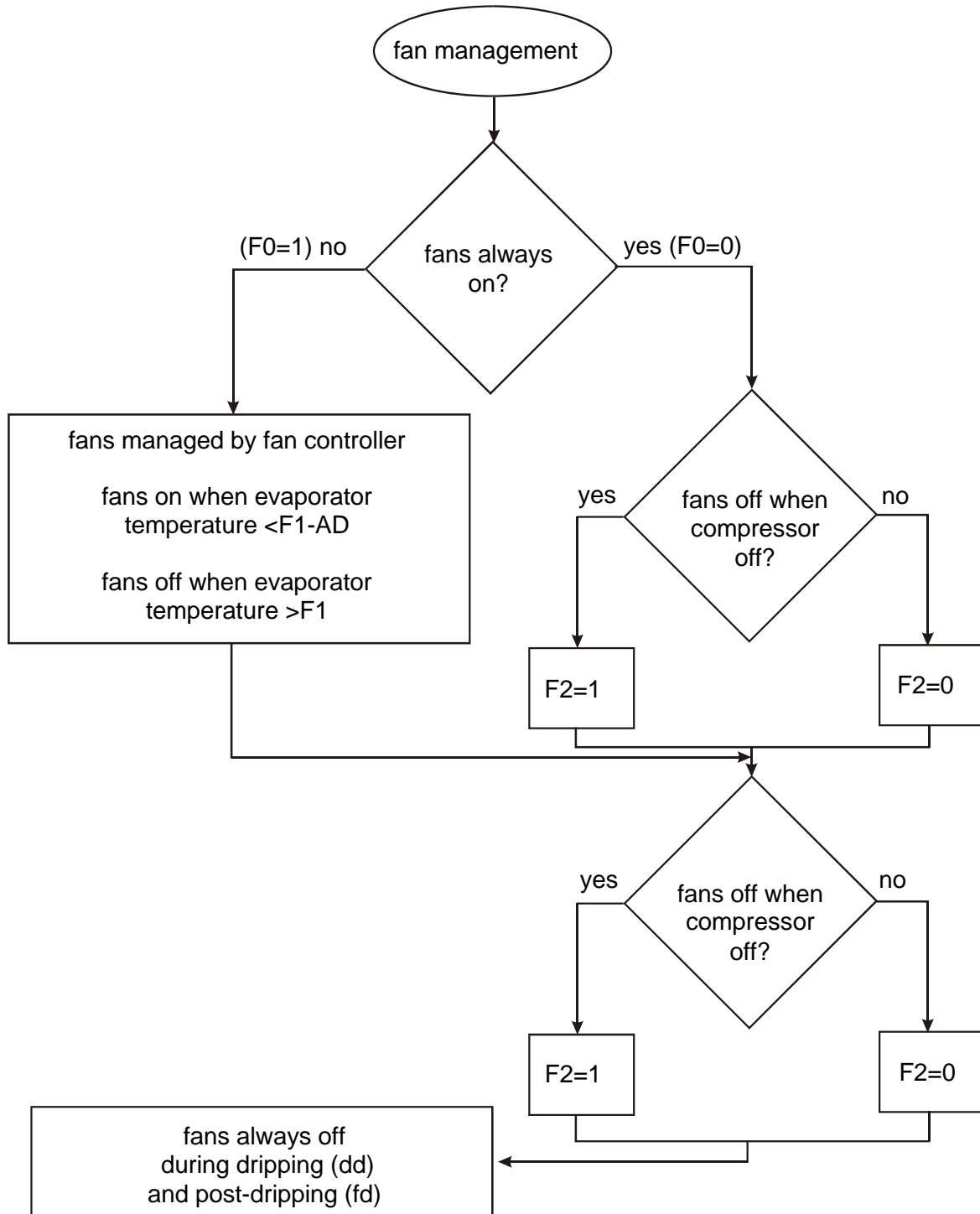

Fig. 4.9.2

Warning: for correct operation the post-dripping phase must be preceded by the dripping phase for a time greater than zero (**dd>0**).

4.10 H = other settings

	alarm parameters	type	min	max	uom	def
H0	serial address	C	0	199	-	1
H1	special configurations: mod. S – enable defrost model with alarm relay –relay activation state	C	0	1	flag	1
H2	disable keypad (0=no, 1=yes)	C	0	1	flag	1
H4	enable buzzer 0 = enabled	C	0	1	flag	1
H5	identification code set only by serial	C	-99	99	byte	10
t	external parameters (optional modules)	F	-127	127	byte	-

Tab. 4.10.1

H0: serial address

Assigns the instrument an address which it responds to when connected to a supervisory or telemaintenance system.

Def.: **H0** = 1. Available on all models.

Warning: **H0** = 0 is reserved.

H1: special configurations

This parameter defines special functions which vary according to the model.

PJ32S (codes PJ32S0E*, S6E* and PJ32S0P*) can operate as simple thermostats (**H1**=0) or as thermostats and defrost controls for static units at normal temperature (defrost on compressor stop, **H1**=1).

This function can be used only for version S with one probe, in that the models which allow the connection of the product probe are programmed as Y models, and for these units defrost is always available.

Def.: **H1**=1, operation with defrost.

PJ32 with alarm relay

H1 sets the operating logic for the alarm relay. If set to zero (0) the relay is energised when the alarm is active, if set to one (1) the relay is de-energised in the event of an alarm. The only model which currently features the alarm relay is the PJ32S20*.

Def.: **H1**=1, relay not energised in the event of an alarm.

Warning: the S models with alarm relay (cod. PJ**S2*) are programmed so as to be able to set the alarm output logic. The programming is thus as for X type instruments, with all the corresponding parameters. The defrost function is thus not set using **H1**, but rather using the parameters corresponding to the defrost.

H2: disable keypad

Parameter **H2** can be used to disable the modification of the set point and the other operating parameters when the instrument is located in areas which are accessible to the public.

With the **keypad disabled**, (**H2** = 0) the set point and type **F** parameters can not be modified. Their value can however be displayed. Type **C** parameters, which are password protected, can **also be modified** following the procedure described below. Modification of parameter **PS** is always allowed. Furthermore, the normal functions of the buttons are also blocked: start continuous cycle and defrost.

Def.: **H2**=1

H4: disable buzzer

Disables the operation of the buzzer.

Def.: **H4** = 0 buzzer enabled. Available on PJ32S and X.

H5: identification code

Assigns the instrument an identification code that can be useful in identifying the various set-ups of the parameters used for different models of machines. The value is display-only; it can be set using the serial connection (with the key or a supervisory system).

A positive value should be set (from 1 to 99), if any parameter, including the set point, is modified using the keypad, the value set becomes negative (with the same value); in this way any modifications to the parameters from the initial set-up can be checked. Using the programming key, the minus sign - can be cancelled.

Def.: **H5** = __ (value depending on the model). Available on all models. Always visible at level F.

Warning: the values from 0 to 31 are used by CAREL to identify the basic models.

t: parameter for expansion modules

Displays and modifies the parameters present on the optional RS485 serial modules and HACCP module.

The operating mode is described in the manuals for the optional modules.

Available on all models.

5. OPERATING STATES

The indication LEDs can have 3 states:

- **off**, when the function indicated or the actuator in question is not in operation;
- **on**, when the function indicated or the actuator in question is in operation;
- **flashing**, when the operation is blocked by an alarm event, by a delay pending or by a specific status of the multifunction input.

There are however special machine conditions in which the status of the signal LEDs are not immediately recognisable. For convenience we have shown as follows the states of the LEDs in these operating modes.

special states	comp LED	def LED
interval of defrost / normal operation	↔	off
defrost request / stand-by	↔	flashing
defrost in progress	↔	on
dripping	off	off
post dripping	↔	Off
compressor request (stand-by)	flashing	↔
continuous cycle (stand-by)	flashing	↔
continuous cycle (running)	flashing in 2 cycles (*)	↔

Tab. 5.1

The symbol ↔ indicates that the LED can be either on, off or flashing, according to the other parameters and environmental conditions (temperature, set point, differential, etc.). The general description on the status of the LEDs, provided above, is thus valid.

The alarm LED is on only during an alarm, and goes off automatically if the alarm is auto-reset or following a reset from the keypad, if the alarm is no longer present. Also see Tab. 7.1.1.

(*) the continuous cycle signal is shown on the compressor LED by a special sequence: two flashes and a long period with the LED ON.

6. PARAMETERS - MODIFICATION





The instruments in the PJ32 series are managed by a microprocessor which allows the operation of the control to be adjusted to effective needs. For this purpose, there are special **operating parameters**. These parameters have been grouped into two families:

- **frequent** parameters (hereafter indicated as type **F**);
 - configuration parameters (type **C**), whose selection is protected by a code, called the password, to prevent unwanted tampering.
- Each parameter can be defined as a frequent parameter or a configuration parameter by setting it using the serial connection or the programming key.

The parameters can be modified from the front keypad and, where the necessary options are featured, using the serial connection. To modify the parameters from the front keypad, proceed as follows.









6.1 Modifying the set point and differential

The instrument has a set point of 4°C. This can be modified as follows:

1. press the  button for a second to display the value of the set point;
2. after an instant, the previously set value starts to flash;
3. increase or decrease the value of the set point using the  and/or  buttons until the required value is displayed;
4. press  again to confirm the new value.

Setting the differential (control hysteresis - parameter rd).

The instrument is pre-programmed with a differential of 2 degrees. This can be modified as follows:



1. press the  button for more than 5 seconds (*);
2. the display shows the code of the first modifiable parameter (**PS**);
3. press the  button or the  button until the code **rd** is displayed;
4. press  to display the associated value;
5. increase or decrease the value using the  and/or  buttons until the required value is displayed;
6. press  again to temporarily confirm the new value and move to the display of the parameter code;
7. press the  button for 5 seconds to save the new value and exit the modify parameters procedure.

(*) during an alarm the  button must be pressed briefly to silence the signal (relay or buzzer) before being able to access the modify parameters procedure.





Warning: the parameter **rd** is normally visible at level F, if not, enter the password (to access the type C parameters).

6.2 Accessing the parameters

To access the type F parameters









1. press the  button for more than 5 seconds (see (*) on previous page);
2. the display shows the code of the first modifiable parameter (**PS**);
3. use the  and/or  buttons to scroll all the type **F** parameters.

To access the type C parameters

1. access the type **F** parameters, select parameter **PS** (password) using the  button;
2. the display shows 00;
3. press the  or  button until 22 is displayed (password);
4. confirm using ;
5. the display shows the code of the first modifiable parameter (all **F** and **C** parameters are visible).



6.3 Modifying the parameters

After having displayed the first parameter, either type **C** or type **F**, proceed as follows:



1. press  or  to reach the parameter which needs to be modified;
2. press  to display the associated value;
3. increase or decrease the value using the  or  buttons, until the required value is displayed;
4. press  to **temporarily** save the new value and return to the display of the parameter code;
5. press  or  again to reach the next parameter which needs to be modified; repeat the operation from point 2.

6.4 Saving the new values assigned to the parameters and exiting

Press the  button for 5 seconds to definitively save the new values.

IMPORTANT WARNING: only pressing the  button for 5 seconds moves from the temporary to the definitive saving of the modifications. Therefore, if power is disconnected from the instrument before pressing , all the modifications made and temporarily saved will be lost.

6.5 Exiting the procedure without modifying the parameters

1. do not press any button for at least 60 seconds (exit by TIME OUT). In this way, the instrument returns to normal operation without saving any of the modifications to the parameters.
2. select the parameter **PS**, enter using  and when the value displayed is 00 press  again.

6.6 Parameters – summary table

	parameters	type	min	max	uom	def	notes
PA	password	F	00	+199	-	22	
/	probe parameters						
/C	ambient probe calibration (x10 value in tenths)	F	-127	+127	°C/°F	0	
/2	measurement stability	C	1	15	-	4	
/4	display first/second probe (0=first=ambient)	C	0	1	flag	0	
/5	°C /°F (0=°C, 1=°F)	C	0	1	flag	0	
r	control parameters						
rd	control differential (hysteresis)	F	0	+19	°C/°F	2	0=0,5 °C/°F
r1	minimum set allowed to the user	C	-50	r2	°C/°F	-50	
r2	maximum set allowed	C	r1	127	°C/°F	60	
r3	enable alarm Ed (0=no,1=yes)	C	0	1	flag	0	
r4	automatic variation of the set point in night-time operation (that is when the curtain switch is closed, when A4=4)	C	-20	+20	°C/°F	3.0	
c	compressor parameters						
c0	compressor start delay at instrument on	C	0	15	min	0	
c1	minimum time between 2 successive starts of the compressor	C	0	15	min	0	
c2	minimum compressor off time	C	0	15	min	0	
c3	minimum compressor on time	C	0	15	min	0	
c4	safety relay (0=OFF, 100=ON). See Duty setting	C	0	100	min	0	
cc	continuous cycle duration	C	0	15	hours	4	
c6	alarm bypass time after continuous cycle	C	0	15	hours	2	

Tab. 6.6.1
follows

continued

d defrost parameters							
d0	type of defrost (0= heating element, 1= hot gas, 2= water or element by time, 3= hot gas by time)	C	0	3	flag	0	
dI	interval between two defrosts	F	0	199	hours	8	
dt	end defrost temperature	F	-50	+127	°C/°F	4	
dP	maximum defrost duration or effective duration when d0 =2 or 3	F	1	199	min	30	
d4	defrost at instrument on (0=no, 1=yes)	C	0	1	flag	0	
d5	defrost delay when the unit is turned on or from digital input (A4 or A5 =4)	C	0	199	min	0	
d6	display off during defrost (0=no, 1=yes)	C	0	1	flag	1	
dd	dripping time after defrost	F	0	15	min	2	
d8	alarm bypass time after defrost	F	0	15	hours	1	
d9	priority of defrost over compressor protection (0=no, 1=yes)	C	0	1	flag	0	
d/	display defrost probe temperature	F	-	-	°C/°F	-	
dC	time basis (0=hours/min, 1=min/s)	C	0	1	flag	0	
A alarm parameters							
A0	alarm and fan differential	C	0	+19	°C/°F	0	
AL	low temperature alarm (indicates the maximum variation allowed in respect to the set point). If set = 0 excludes the low temperature alarm	F	0	+127	°C/°F	0	
AH	high temperature alarm (indicates the maximum variation allowed in respect to the set point). If set = 0 excludes the high temperature alarm	F	0	+127	°C/°F	0	
Ad	temperature alarm delay	C	0	199	min	0	
A4	digital input configuration	C	0	4	-	0	
A7	detection time delay for the alarm input (A4 = 1)	C	0	199	min	0	
F fan parameters							
F0	fan management: 0 = fans always on except specific phases (see parameters F2 , F3 , and Fd); 1=fans controlled according to the temperature of the evaporator and excluding the phases F2 , F3 , Fd .	C	0	1	flag	0	
F1	fan on temperature: if F0 =1; F1 is the fan ON set point (evapor. T < set point(F1))	F	-50	+127	°C/°F	5	
F2	fans off with compressor off (0=no, 1=yes).	C	0	1	flag	1	
F3	fans off in defrost (0=no, 1=yes).	C	0	1	flag	1	
Fd	off in post dripping.	F	0	15	min	1	
H other settings							
H0	serial address		0	199	-	1	
H1	PJ32S 0=T op.; 1=S op. with defrost PJ32C selection of alarm relay operation 0=alarm normally not energised, 1=alarm normally energised	C	0	1	flag	1	
H2	0=buttons disabled;	C	0	1	flag	1	
H4	only PJ32S 0=buzzer enabled 1=buzzer disabled	C	0	1	flag	0	
H5	identification code (or model number)	F	-99	+99		10	(*)
t	external parameter (used only for the external options)	F	-127	+127	-	-	

Tab. 6.6.1

(*):parameter **H5** can only be set using the serial connection and is always visible at level F.

7. ALARMS, TROUBLESHOOTING

7.1 Anomalous or special operating conditions

The instruments in the PJ32 series are able to automatically detect the main malfunctions with the consequent activation of the following actions:

- the malfunction is signalled on the display with the corresponding alarm code. In particular, the instrument displays the alarm code and the temperature read by the probe, alternating. In the case of more than one alarm, these are displayed in sequence:

- the red LED on the  button is ON or the graphic symbol (2) appears on the display;
- for some alarms the internal buzzer, if present, sounds;
- for the same alarms the alarm relay, if present and configured as an alarm output, is activated.

Pressing the  button silences the buzzer, while the red LED and the alarm relay go off only when the cause of the alarm no longer exists. The alarm codes are shown in the following table:

alarm code	buzzer and alarm relay	alarm description	models on which present
E0	active	probe control error	all
E1	not active	defrost probe error	all except S and X
IA	active	external alarm immediate or delayed by A7	all, if the digital input is present
L0	active	low temperature alarm	all
HI	active	high temperature alarm	all
EE	not active	data error	all
Ed	not active	end defrost for time-out	all except PJ32S
dF	not active	defrost in progress	all

Tab. 7.1.1

7.2 Description of the main signals and alarms

LED flashing

The activation of the corresponding function is delayed by a timer, on stand-by for an external trigger or inhibited by another procedure in progress. For example, if a continuous cycle is in progress and a defrost is requested, the latter awaits the end of the continuous cycle and the corresponding LED (defrost) flashes.

E0 on or flashing

control probe error:

- probe not working: the probe signal is interrupted or short-circuited;
- probe not compatible with the instrument;

The alarm signal **E0** stays on if there is just one alarm present (the value of temperature is no longer displayed), while it flashes if other alarms are present or the second probe is displayed.

E1 flashing

evaporator probe or food storage probe error:

- probe not working, the probe signal is interrupted or short-circuited;
- probe not compatible with the instrument;

IA flashing

alarm from multifunction digital input, immediate or delayed:

- check the multifunction input and the parameters **A4** and **A7**.

L0 flashing

low temperature alarm. The probe has read a temperature which is lower than the set by a value greater than parameter **AL**:

- check the parameters **AL**, **Ad** and **A0**.

The alarm is automatically reset when the temperature returns within the set limits (see parameter **AL**).

HI flashing

high temperature alarm. The probe has read a temperature which is higher than the set by a value greater than parameter **AH**.

- check the parameters **AH**, **Ad** and **A0**.

The alarm is automatically reset when the temperature returns within the set limits (see parameter **AH**).

This alarm can be also be activated by the HACCP module; for a description see the corresponding chapter.

EE shown during operation or when the unit is turned on
error in reading the parameters from the memory. See **Data error**.

Ed flashing

The last defrost ended after exceeding the maximum duration rather than reaching the end defrost set temperature:

- check parameters **dt**, **dP** and **d4**;
- check the efficiency of the defrost function.

The message will disappear if the next defrost ends at the set temperature.

dF flashing

defrost in progress:

- this is not an alarm signal but rather an indication that the instrument is performing a defrost. It is displayed only if parameter **d6** = 0.

7.3 Data error

In special operating conditions the instrument may detect errors in the internal storage of the data. These errors may compromise the correct operation of the instrument. If the microprocessor detects a data storage error, display shows the code **EE**.

The instrument tries repeatedly to reset the correct operating conditions, and this is indicated by the three dashes --- (reset) alternating with the code described above.



Warning: if the serial interface to the supervisor (PJOPZ48500) or the HACCP module is connected, one possible cause of this behaviour may be incorrect wiring or a fault in the interface itself. In this case, disconnect the interface and check if the problem remains.

If the anomalous situation remains, the control must be replaced. If on the other hand the message disappears, the control can still be used. When the **EE** error occurs frequently and/or is hard to resolve, it is recommended to have the control checked, in that the original accuracy may not be guaranteed.

It is good practice to investigate the cause of this type of error so as to prevent it occurring again. **In particular, carefully read** the chapter on **INSTALLATION** and the paragraph **Special and general warnings**.

7.3.1 Loading the default parameters

The default values of the parameters can be restored by following the procedure described below:

- disconnect power to the instrument;
- press and hold the  and  buttons, and reconnect power to the instrument;
- the display shows the message - - - followed by **CF**;
- after some seconds the instrument will start working according to the default configuration. Any of the F and C parameters which differ from the default configuration must be modified.

IMPORTANT WARNINGS

- the procedure described above resets the instrument and assigns the default parameters. **As a result, all modifications made to the operating parameters will be lost;**
- given the delicacy of this operation, the procedure must be performed by specialist personnel. This procedure does **not damage** the instrument, but rather resets its original purchase configuration. Therefore, if the operating parameters have been modified in a disorganised fashion, to the point where the control is unworkable, it can be reset to its original configuration;
- the setting of level F visibility for the parameters is not modified by the procedure;
- if a programming key is used the reset operation is much simpler, as long as the key contains the required configuration, or it can be copied from another instrument programmed in the same way. In this case, the visibility flags are updated.

7.4 Troubleshooting

The following table shows other anomalous operating situations which may arise in the various models. The more frequent causes are indicated and a number of checks are suggested.

problem	CAUSE	checks
the compressor does not start (signalled by compressor LED flashing)	<ul style="list-style-type: none"> compressor delay on post defrost dripping in progress 	check parameters c0 , c1 and c2 and dd
the temperature is over the set limit but there is no alarm message and the buzzer, if present, does not sound	alarm delay on	check parameters Ad , c6 , d8
the alarm IA is signalled (multifunction input) without this actually being active	the multifunction input generates an alarm when the contact opens	check the connection of the input and if it is closed in normal operation
the alarm connected to the multifunction input is not detected	alarm delay on or parameter setting error	check if A4 =1 check the status of the digital input check A7
the defrost is not activated	<ul style="list-style-type: none"> defrost cycle too short (dP) interval between defrost dI=0: in this case the defrost is not activated 	check parameters dP and dI and H1 for S models
	the end defrost temperature is too low or the evaporator temperature is too high	check parameters dt and d/ defrost probe
the manual defrost is not activated and the defrost LED flashes	the compressor protection times are active	check parameter d9 (select d9 =1, see WARNINGS)
the high temperature alarm appears after a defrost	the alarm delay after defrost is too short or the alarm threshold too low	check parameters d8 and AH
the display remains off even after the defrost	the ambient temperature has not yet reached the set value or the time d8 has not elapsed	wait or reduce d8
after modifying a parameter the control continues to operate with the old values	<p>the instrument has not updated the old value or the parameter programming procedure was not concluded correctly, that is by pressing the  button for 5 seconds</p>	turn the instrument off and on again or re-program the parameters correctly
for the C models, the fans do not start	<ol style="list-style-type: none"> a delay in the activation of the compressor and the fans has been selected if F0=1 (fans managed by fan controller) <ul style="list-style-type: none"> the evaporator is <hot>: the evaporator temperature can be read by selecting the parameter /d; dripping is in progress; F1 (fan off temp) too low. post dripping delay is on if F0=0 <ul style="list-style-type: none"> F2=1 and the compressor is off dripping is in progress post dripping fan off is in progress 	<ol style="list-style-type: none"> check parameter c0 parameters F0, F1, Fd, dd and d/ parameters F0, F2, dd and Fd

Tab. 7.4.1

8. AVAILABLE ACCESSORIES

8.1 Key for copying the parameters

Duplicates the configuration of an instrument (set values of all the parameters and visibility flags), allowing them to be transferred to other instruments, as long as these have the same hardware configuration (same code).

The key consists of a remote control type box with a connecting cable to the serial port of the instrument, and features an on/off button and a two-colour signal LED (red/green).

It is powered by a 12Vdc alkaline battery, such as the Philips VR32 or Duracell MN21, or equivalent.

The key must be connected to the instrument when it is off (it doesn't need to be powered), as the power to the instrument is supplied by the key itself.

Pressing and holding the activation button transfers the data. The two-colour LED signals the operating status, indicating the execution and completion of the data transfer and any errors. The maximum duration of the operation is around 12 seconds; during this period the instrument remains off, after which it starts in normal mode.

During the first 12 seconds the consumption of current is reduced, in that the instrument's LEDs and display are not turned on due to their high consumption. The button should not be pressed longer than the time required to complete the operation, so as not to discharge the battery too quickly.

The possible operations are the following:

1. read the parameters from the connected instrument and save them to the key. This operation is always possible and is activated by setting the two dip-switches 1,2 to position OFF and pressing the activation button for the necessary time;
2. write the parameters from the key to the connected instrument. This is performed by setting dip-switch 2 to position ON and dip-switch 1 to OFF, and pressing the activation button. This operation can only be performed if the parameters contained in the key (model) are compatible with the connected instrument;
3. reset the modify parameters flags (minus sign – for **H5**). This is performed by setting dip-switch 1 to position ON and dip-switch 2 to OFF, and pressing the activation button. This operation is always possible, and the values of the parameters, apart from the flag **H5**, are not modified.

The indications of the two-colour LED are the following:

- on → for a brief the red LED turns on at low intensity;
- data transfer → the red LED turns on at high intensity; **the activation button must not be released during this period;**
- operation completed → the green LED turns on, the operation is concluded.
- in the event of errors, the red and green LEDs will flash to indicate various causes:
 1. instrument disconnected or no response;
 2. low power (battery);
 3. instrument model not compatible;
 4. transfer error;
 5. instrument EEPROM error.

For a more complete description of the causes of these errors, please refer to the key instruction sheet.



Fig. 8.1.1

8.2 Serial adapter for RS485 network

8.2.1 General characteristics

The optional RS485 serial module allows the plug-in instruments to be connected to the CAREL supervisory network, providing complete control and monitoring of the operation of the plug-in instruments connected.

The system features the possibility of connecting up to 200 units, with a maximum total connection length of 1000 m.

Connection to the supervisor requires the standard accessories (PC485KIT00), and a termination resistor of 120Ω to be placed on the terminal block of the last instrument.

In respect to the RS485 serial networks with IR32 instruments, the serial module provides electrical insulation between the serial network ground and each connected instrument, thus significantly reducing noise problems in larger installations.

Wiring example in the case of serial connection of the instruments:

MAIN	230Vac mains power
TRF	3VA 12Vac transformer for PJ32
RS485	RS485 serial module for plug-in
RS485 module terminals	1 and 2: 230Vac power; 3: RS485 line (-); 4: RS485 line (+); 5: RS485 ground and shield \perp

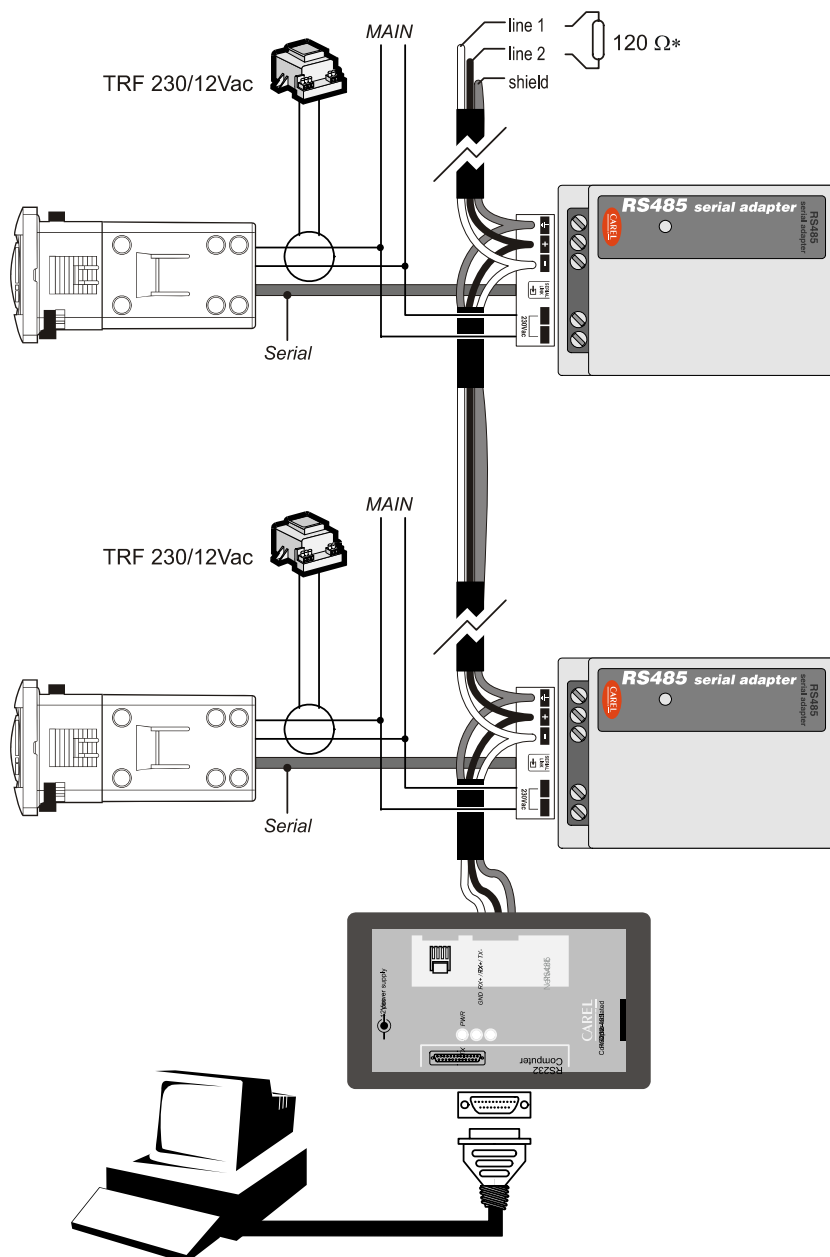

Fig. 8.2.1

Components for serial connection to a supervisor system:

- **PC485KIT00:** serial adapter from RS485 to RS232 for connecting to a PC or CAREL supervisor network, complete with RS232 serial adapter and mains power supply.
- **RS485 serial adapter:** serial adapter with twisted pair and shield for RS485 connection.

The following connections must be respected:

serial adapter shield: connect to adapter GND and module \perp ;

line 1: connect to adapter Rx+/Tx+ and module +;

line 2: connect to adapter Rx-/Tx- and module -.

* At the end of the line, on the last RS485 module, connect the 120 Ω terminal resistor between terminals + and -.

8.2.2 Installation

The mounting of the RS485 serial module uses a standard DIN rail, for wall-mounting an adapter is supplied (DIN rail plate) to fasten to the wall, onto which module is mounted.

The module-instrument connecting cable is supplied with the module and is 50 cm long; the RS485 module should thus be located at a distance that is compatible with this connection, which can not be extended.

The electrical connections to be made are the following:

- module instrument connecting cable (50 cm long), connected to the connector on the Top version plug-in instruments;
- 230Vac mains power connections to terminals 1 and 2, as in Figure 8.2.1 (indicated by **230Vac** on the module);
- RS485 serial connection on terminals 3, 4, 5 as in Figure 8.2.1 (indicated by **—**, **+** and **≡** on the module).

Warning: The serial adapter recommended for the connection is a serial adapter with twisted pair and shield, 0.5A rating, with a 1.5mm² cross-section (e.g. AWG 22-24). The last instrument on the line must be fitted with the 120 Ω terminal resistor.

8.2.3 Setting the operating parameters

The serial module features two operating parameters, for setting the speed of serial transmission and to assign a static address to the module when the function is enabled. All the parameters can be displayed and modified using the display and the buttons on the connected plug-in instrument. The parameters can be accessed using parameter t on plug-in instrument. For this operation parameter **H0** on the plug-in instrument must also be set.

8.2.4 Serial adapter parameters

	parameters	type	min	max	uom	def
H0	serial address (plug-in instrument)	C	0	199	-	1
tS	transmission speed (baud-rate)	F	0	1	-	0
t0	local address (static)	F	0	127	-	0

Tab. 8.2.4.1

H0: serial address (plug-in instrument parameter)

The setting of this value defines the address of the instrument in the supervisory network, and is required for the operation of the adapter when other instruments are connected.

The value 0 is reserved (can not be used); in the supervisory network the connected instruments must all have different addresses; the allowable values range from 1 to 199.

Def.: 1 Available on all models.

tS: transmission speed

Defines the speed (baudrate) of communication between the adapter module and the supervisor PC. With the parameter set to 1 the speed is 9600 baud, with a value of 0 the speed is 19200 baud. The communication speed must be the same as that defined in the supervisor program.

Values from 0 to 1 Def.: 0 Available on all models.

t0: local serial address

Defines a local address as an alternative to **H0**. This parameter allows an **independent** address to be defined for the connected instrument. The parameter is visible only if custom-enabled by CAREL (*).

This situation can be useful when the instrument connected to the module is expected to change frequently (e.g. in test situations).

Def.: 0; values can range from 0 to 127, the value 0 is reserved (can not be used).



(*)Enabling of operation with a local address is performed in the CAREL factory and must be requested at the moment of ordering.

8.2.4.1 Accessing and modifying type t parameters

The method for displaying and modifying the added parameters present in the options (t parameters) is different from that used for the standard parameters on the instrument. The main difference is the fact that all the t parameters are scrolled only using the







button and not the **Up** and **Down** buttons. The procedure is the following:



- access the parameters of the expansion module. Select parameter t using the standard operation for the plug-in instrument:
 1. press the  button for 5 seconds to access the first level parameters;
 2. if parameter t is visible at the first level (F parameters), scroll the parameters using the  or  buttons until parameter t is selected;
 3. if the parameter is not visible at the first level, access the second level (C parameters) by entering the correct password and then select t, as in point 2.

Warning: for further information, refer to the chapter **PARAMETERS - MODIFICATION**.

- Transfer from the expansion module, with parameter t displayed, of the complete description of the first parameter displayed on the instrument (for example, **t S** for the baud rate):

1. press the  button to display the value of the parameter;
2. use the  and  buttons to modify the value displayed, increasing or decreasing it respectively;
3. press the  button again to confirm the modified value and exit the display of the value;
4. the module then brings up the next parameter, and displays its the description (for example, **t 0** for the static address);
5. repeat points 1 2 and 3 to display and if necessary modify the value;
6. pressing the  repeatedly scrolls all the parameters which can be displayed; after the last parameter the display starts from the first again.

The display of t parameters is exited as follows:

1. by time-out, after 30 seconds inactivity of the buttons;
2. when displaying the description of a t parameter, pressing the  or  button moves to the next or previous parameter on the plug-in instrument.

The parameters on the module are saved immediately, and does not require confirmation by pressing the  button for 5 seconds.

When modifying the value, two segments of the left-most digit signal that the minimum and maximum values have been exceeded (segments 1 and 2 in Fig. 8.2.4.1.1). If an out-of-range value is confirmed, the maximum or minimum value is saved, according to whether the upper or lower limit has been exceeded.

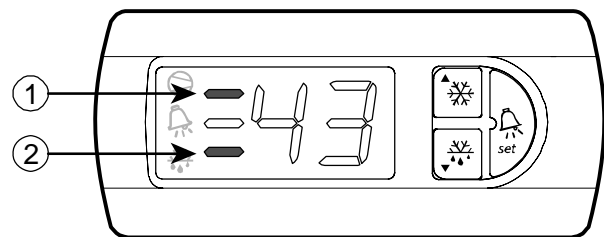

Fig. 8.2.4.1.1

8.3 Additional HACCP module

8.3.1 General characteristics

The optional HACCP module expands the control functions of the plug-in family instruments by adding temperature control with the recording of alarm situations due to the exceeding of the maximum temperature thresholds for significant periods, which may derive from operating anomalies either in the controlled machines or due to power failures. The added control functions are designed to help the user monitor the food storage temperature in order to comply with the checking and recording phases required by the HACCP standards on correct food storage.

As an option a function can be enabled to generate defrost requests programmed at set times.

HACCP alarm management: The control performed by the al HACCP module features the management of two different events which may be dangerous for correct food storage:

1. **HA alarm:** if the control temperature is higher than a maximum value for a longer than a set delay time. The threshold value corresponds to the value set on the plug-in instrument for the high temperature alarm (**SET+AH**), the delay time corresponds to the sum of the times set for two parameters: parameter **Ad** on the plug-in instrument, and parameter **tr** on the HACCP module;
2. **HF alarm:** power failure for an extended period (greater than one minute) with temperature at power resumption higher than the maximum value (**SET+AH**).

In both cases an alarm is generated, with a signal on the display of the plug-in instrument and the LED, and alarm relay or buzzer active if present. Furthermore, the status of the alarm is recorded, and can then be displayed.

8.3.2 Installation

The HACCP module is mounted using a standard DIN rail, for wall-mounting an adapter is supplied (DIN rail plate), to be fastened to the wall and onto which the module can be mounted.

The module-instrument connecting cable is supplied with the module and is 50 cm long; the HACCP module must thus be placed at a distance that is compatible with this connection, which can not be extended. The module is also powered directly by the plug-in instrument using this connection.

8.3.3 Setting the main operating parameters

During installation the main parameters to be checked are listed here below; in particular, please remember that two parameters determine the enabling or disabling the detection of the HACCP alarms:

AH: Temperature alarm threshold

if set to 0 disables the detection of alarms **HA** and **HF**, any pending alarms are not cancelled;

if set to a value > 0 means the alarm threshold is set to the value = **SET+AH** and the alarm detection is enabled.

tr: HACCP alarm detection delay time

if set to 0 disables the detection of alarms **HA** and **HF** (as above);

if set to a value > 0 means the delay time is equal to **Ad** + **tr** (**Ad** is the alarm delay time parameter of the connected plug-in instrument).

tu, th, t': setting the clock: day of the week, hours and minutes of the internal clock

to: display parameter and reset alarms.

During installation some HACCP alarms will probably have to be cancelled from the start-up of the machines. Setting the value to 0 resets all the pending **HA** and **HF** alarms, including all the variables for recording the status of the alarms.

For a complete description of the parameters, please refer to the paragraph **HACCP module parameters**.

8.3.4 Parameters - description

The HACCP module uses some parameters from the plug-in instrument and its own parameter for the alarm recognition algorithm, and produces a set of variables for recording the **HA** and **HF** events if these occur. It also features parameters for setting the clock and entering up to eight defrost events at programmed times.

All the parameters can be displayed and modified using the display and the buttons on the connected plug-in instrument. The parameters can be accessed using the **t** parameter on the plug-in instrument; when displaying the parameters some segments of the left-most digit are used as indicated in the figure.

The display and modification procedures are the same indicated in the paragraph on accessing and modifying the **t** parameters of the RS485 serial module.

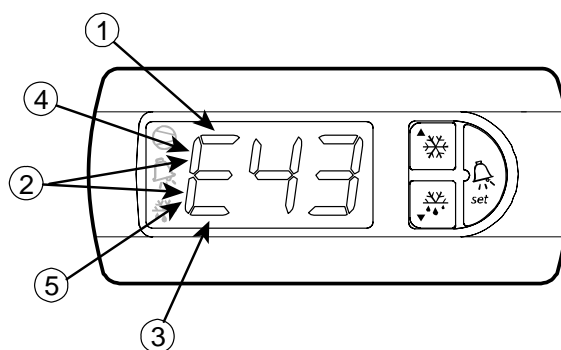

Fig. 8.3.4.1

8.3.5 Parameters of the plug-in instrument

	parameters	type	min	max	uom	def
SET	control set point	-	-50	127	°C/°F	4
AH	high temperature alarm threshold	F	0	127	°C/°F	0
Ad	temperature alarm delay time	C	0	199	min.	0

Tab. 8.3.5.1

SET: value of the control set point of the plug-in instrument

This is read directly from the value set on the instrument.

AH: value of the high temperature alarm threshold

This is read directly from the value set on the instrument. Together with the **set point** it determines the value of the temperature threshold for the detection of alarms **HA** and **HF** (respectively high temperature and power failure alarms).

Threshold = **SET**+**AH**.

Warning: **AH** = 0 disables the detection of the alarms.

Ad: Value of the temperature alarm detection delay

This is read directly from the value set on the instrument. It is used together with parameter **tr** in the HACCP module to determine the value of the delay in recognising the **HA** alarm event.

8.3.6 HACCP module parameters

left segment	code	parameter description	min	max	uom	def
	tu	day of the week of the internal clock	1	7	-	1
	th	hour of the internal clock	0	23	hours	0
	t'	minutes of the internal clock	0	59	min	0
	tr	HA alarm delay	0	127	min	0
	to	global reset of alarms HA and HF	0	1	-	0
①	t1-8	defrost day of the week	0	10	-	0
②	t1-8	defrost hours	0	23	hours	0
③	t1-8	defrost minutes	0	59	min	0

Tab. 8.3.6.1

tu: day of the week of the internal clock

Displays/Sets the day of the week for the clock. The possible values are from 1 to 7, corresponding to Monday, ..., Sunday in order.

th: hours of the internal clock

Displays/Sets the current hours for the clock. Values from 0 to 23.

t': minutes of the internal clock

Displays/Sets the minutes for the clock. Values from 0 to 59.

The setting of the internal clock is important for the correct recording of the **HA** and **HF** alarms, the times of which are also recorded.

tr: added HA alarm delay

This parameter is saved in the HACCP module and is different from the alarm detection delay (parameter **Ad**) of the plug-in instrument. The **HA** alarm detection delay is the sum of the two **tr + Ad**.

Warning: if **tr** = 0 the detection of the **HA** and **HF** alarms is disabled.

Def.: 0 null delay and HACCP functions disabled

to: global reset of alarms HA and HF

This parameter has two functions:

- display of the status of alarms **HA** and **HF** (1 = alarm present);
- reset the alarms if set to zero.

The parameter is displayed only if there are alarms present, otherwise it is not displayed, nor are all the parameters for recording the status of the alarms (see below).

The reset function sets all the parameters for recording the status of alarms **HA** and **HF** to zero.

t1 - t 8 parameters to set the request for programmed defrost

These parameters are used to define eight defrost events, set by time (day, hour, minute). At the set times the HACCP module sends a defrost request to the connected plug-in instrument. These parameters are normally not displayed, in that they refer to distinct operations in respect to the effective HACCP functions. They can be displayed and modified only after having entered the correct "password" (parameter **PS**) before accessing the t parameters.

To set the values, there are three parameters for each of the eight events t1,... t8:

- the parameter for the day is indicated by a segment (1 in Fig. 8.3.4.1) which appears together with the number of the event (t1,...t8) and is indicated by ① t1,... ① t8
- the parameter for the hours is indicated by a segment (2 in Fig. 8.3.4.1) and is indicated by ② t 1,... ② t8
- the parameter for the minutes is indicated by a segment (3 in Fig. 8.3.4.1) and is indicated by ③ t1,... ③ t8

① t1,... ① t8: defrost event day

This parameter defines the day of the week that the defrost is performed for one the eight possible events, a single day or group of days can be selected. The parameter can have the following values:

value	description
0	null event; in this case the two parameters associated to the hours and minutes are not displayed
1, ..., 7	selection of a single day Monday,... Sunday
8	selection of weekdays: from Monday to Friday
9	selection of weekends: Saturday and Sunday
10	all days

Tab. 8.3.6.2

② t1,... ② t8: defrost event hour

This parameter defines the hour at which the defrost is performed, the possible values are from 0 to 23.

③ t1,... ③ t8: of defrost event minute

This parameter defines the minute at which the defrost is performed, the possible values are from 0 to 59.

8.3.7 Parameters corresponding to the recording of the HA and HF alarms

left segment	code	parameter description	min	max	uom	def
④	tu	day of last HA event	1	7	-	-
④	th	hours of last HA event	0	23	hours	-
④	t'	minutes of last HA event	0	59	min	-
	tA	number of HA events detected (since reset)	0	127	-	0
④	tt	maximum temperature value during HA alarm	-50	127	°C/°F	-50
④	td	maximum duration of the HA events	0	18	hours	0
⑤	tu	day of last HF event	1	7	-	-
⑤	th	hours of last HF event	0	23	hours	-
⑤	t'	minutes of last HF event	0	59	min	-
	tF	number of HF events detected (since reset)	0	127	-	0
⑤	tt	maximum temperature value for HF alarm upon resumption of power	-50	127	°C/°F	-50
	tt	maximum temperature value for HF alarm before power failure	0	127	-	0
⑤	td	maximum duration of the HF event	0	18	hours	0

Tab. 8.3.6.1

The parameters for recording the status provide a detailed description of the **HA** and **HF** alarms which have occurred since the last reset. All the parameters are display-only, they are divided into two distinct groups for **HA** alarms and **HF** alarms, and are displayed only if the relative alarm **HA** or **HF** is effectively present. The parameters are identified using the name associated to a segment of the left-most digit, ④ for the **HA** alarms and ⑤ for the **HF** alarms (see figure). The order of display of the parameters is listed in the table.

In the case of more than one event saved, the recording is of the time of the last event only, the total number of **HA** or **HF** events, the maximum temperature measured during the **HA** and **HF** alarms and of the relative maximum durations.

8.3.8 Operating mode and alarm signals

When the detection of the alarms has been enabled by the correct setting of parameters **AH** and **tr**, the HACCP module performs continuous control, at one minute intervals, of the control temperature, and based on this and the other parameters (alarm threshold and delay times) signals and records the type **HA** alarms, which regard the exceeding of the set temperature limits for extended periods longer than the set delay times. The module also controls the temperature on re-starts after power failures, signalling and recording type **HF** alarms.

HA alarm: arises when the control temperature is above the maximum set (**SET+AH**) for longer than the set delay (**Ad** + **tr**).

The parameter **Ad** sets the alarm delay of the plug-in instrument, on exceeding this time an alarm signal (high temperature) is activated, generated by the instrument itself; this signal can be used as a pre-alarm for the subsequent signal that the total time has been exceeded (**Ad** + **tr**), which determines the actual **HA** alarm. The two parameters allow a maximum duration of 326 minutes to be set.

Any alarm event involving the control probe of the plug-in instrument (**E0**) is considered equivalent to the temperature being greater than the threshold, and thus also determines a **HA** alarm signal after the set delay time.

When the **HA** alarm is detected the following information, regarding the status parameters, is recorded:

- maximum temperature reached during the alarm (above **SET+AH**);
- time the alarm event started;
- duration of the alarm; when the alarm is in progress, the current duration is measured;
- number of events (**HA**) detected.

In the case of a series of alarm events, the information on the alarm is updated:

- the temperature involves the highest value of all the events recorded;
- the time refers to the last event;
- the duration is the longest of all the events recorded;
- the number of events is increased by 1.

HF alarm: Occurs when, after a power failure for an extended period (more than one minute), the control temperature upon resumption of power is above the set maximum (**SET+AH**).

The detection if this alarm is enabled as for the **HA** alarm: **AH** > 0 and **tr** > 0. The delay times in this case are not considered, as the detection of the alarm is instantaneous if the power failure lasts longer than **Ad**, and **Ad** + **tr** also gives the **HA** alarm signal.

When the **HF** alarm is detected the following information, regarding the status parameters, is recorded:

- temperature before the power failure;
- duration of the power failure ;
- time the power failure is detected (instant the power resumes);
- temperature reached on resumption of power;
- number of events (**HF**) detected.

In the case of a series of alarm (**HF**) events, the information on the alarm is updated:

- both temperatures involve the highest value of all the events recorded;
- the time refers to the last event;
- the duration is the longest of all the events recorded;
- the number of events is increased by 1.

Alarm signals: the detection of one of the two alarm events, **HA** or **HF**, is signalled using the LED display of the plug-in instrument, and by activating any alarm devices available on the instrument: alarm LED, buzzer if featured, alarm relay if featured.

HA alarm: the display LED ② shows the **HI** alarm code flashing alternately with the temperature value, the alarm LED ③ is on and the upper segment ① of the left-most digit is on. If present the buzzer and the alarm relay are also activated.

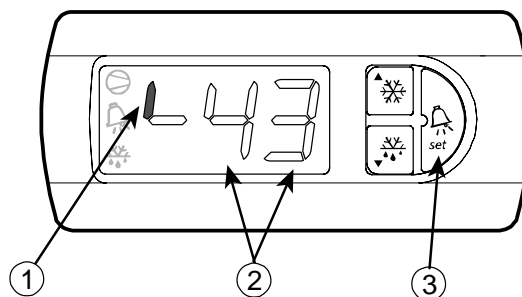

Fig. 8.3.8.1

HF alarm: the display LED ② shows the **HI** alarm code flashing alternately with the temperature value, the alarm LED ③ is on and the lower segment ⑤ of the left-most digit is on. If present the buzzer and the alarm relay are also activated.

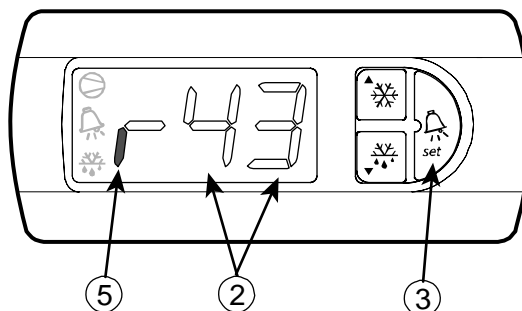



Fig. 8.3.8.2

8.3.9 Cancelling the alarms

In the event of the **HA** or **HF** alarm signal, the signals can be reset, both the signals and the recording of the status can be cancelled completely:

- press the  button for 2 seconds to turn off LED ③, silence the buzzer and deactivate the alarm relay, if present. The display still shows the **HA** or **HF** alarm status (segments ① and ⑤ in the figure) and the alarm code;
- use the parameter **to** to completely cancel the pending alarms, signals and status recording variables.

Warning: resetting the signals or the entire status of alarm cancels the signals requested by the HACCP module; if other alarms detected by the plug-in instrument are present, some signals may remain active.

9. TECHNICAL SPECIFICATIONS

models		PJ32S	PJ32X	PJ32Y	PJ32C
POWER SUPPLY					
very low voltage	12Vac ±10%, 50/60Hz / 12Vdc (11 to 16Vdc)	•	•	•	•
low voltage	230Vac/Vdc, +10/-15%, 50/60Hz	•	•	•	•
	115Vac/Vdc, +10/-15%, 50/60Hz	•	•	•	•
rated power (VA)		3			
accuracy (with reference to the type of probes)					
CAREL NTC (°C)		±1			
PTC (°C)		±3			
type of control probe					
CAREL NTC (10 K at 25°C)		•	•	•	•
PTC (985 Ω at 25°C)		•			
type of defrost probe					
CAREL NTC (10 K at 25°C)				•	•
PTC (985 Ω at 25 °C)					
control range:-50 to 90 °C (-50 to 127 °F)		•	•	•	•
operating conditions: -10 to 50 °C, <80% RH		•	•	•	•
storage conditions:-20 to 70 °C, <80% RH		•	•	•	•
USER INTERFACE					
2 and ½ digit LED display		•	•	•	•
buzzer signal to indicate:		•			
compressor ON (*)		Top/Eco	Top/Eco	Top/Eco	Top/Eco
defrost ON		Top	Top	Top	Top
continuous cycle ON		Top/Eco	Top/Eco	Top/Eco	Top/Eco
alarm event		Top	Top	Top	Top
special functions					
duty setting		•	•	•	•
continuous cycle		•	•	•	•
Multifunction input		•	•		
Multifunction output for alarm relay			•	•	•
serial connection		Top	Top	Top	Top
keypad protection		•	•	•	•
programming		•	•	•	•
MECHANICAL SPECIFICATIONS					
dimensions (mm): 36x81x65		•	•	•	•
clip-on fastening using bracket		•	•	•	•
fastening from front panel using screws		Top	Top	Top	Top
type of environmental pollution: normal		•	•	•	•
ELECTRICAL SPECIFICATIONS					
relay outputs: action type 1C		•	•	•	•
index of protection IP54 for panel mounting		•	•	•	•
connections: screw terminals for cables with min 0.5 mm ² and max 1.5 mm ² cross-section, and up to 2.5 mm ² for crimping terminals		Top	Top	Top	Top
UL approval classification: 250Vac 12/8/5A res. 5/2/1FLA 30/12/6LRA					
EN60730-1 classification: 12(2)/6(2)/5(1) AT 250Vac					
QUALITY AND ACCURACY					
watch dog (self-checking of internal functions)		•	•	•	•

Tab. 9.1

(*): only the **Top** versions feature the LED signals behind the buttons, the other (**Eco**) versions feature only the compressor ON signal using the decimal point of the right-most digit.

9.1 Table summarising the characteristics of the relays used

ELECTRICAL SPECIFICATIONS OF THE RELAYS PRESENT ON THE VARIOUS MODELS	max current 16A resistive	max current 8A resistive	max current 5A resistive	max current 16 A resistive 2 HP
maximum peak current	30A	12A	6A	72A
maximum commutable resistive current	12A	8A	5A	16A
maximum commutable power (250Vac)	3000VA	2000VA	1250VA	4000VA
maximum inductive load at 250Vac	4 A (cos φ=0.7)	2A (cos φ=0.8)	2A	12A (cos φ=0,7)
maximum commutable voltage	250Vac	250Vac	250Vac	250Vac
VDE0435 classification	16(2) AT 250Vac	8(2) AT 250Vac	5(2) AT 250Vac	16A 250Vac
VDE0461 classification	12(2) AT 250Vac	6(4) AT 250Vac		12(12)A 250Vac
UL classification (*) (UL approval of the instrument)	250Vac 12A res. 5FLA 30LRA	250Vac 8A res. 2FLA 12LRA	250Vac 5A res. 1FLA 6LRA	250Vac 12A res. 12 FLA 72LRA
instrument classification as per EN60730-1	12(2) AT 250Vac or 10 (4)A only NO	6(2) AT 250Vac or 8 (3)A only NO	5(1) AT 250Vac	10(10)A 250Vac

Tab. 9.1.1

(*) Minimum T OFF between two following motor load starting is 60 seconds or more.

9.2 Temperature/resistance values for the NTC thermistors

The temperature probes with NTC thermistors, normally used on the PJ32 controls, feature electrical resistance which changes according to changes in temperature. Below are the resistance values corresponding to various temperatures.

Table 9.2.2 lists 3 resistance values for each temperature:

- R_{std} is the typical resistance value at the indicated temperature;
- R_{min} is the minimum value;
- R_{MAX} is the maximum value.

In order to be able to check probe operation, the table shows values corresponding to a number of temperatures.

Table of temperature/resistance values for the CAREL NTC temperature probe. Nominal value: 10 kΩ at 25°C.

temperature (°C)	R_{min} (kΩ)	R_{std} (kΩ)	R_{MAX} (kΩ)
-40	181.10	188.40	195.90
0	26.74	27.28	27.83
20	11.95	12.09	12.23
50	4.08	4.16	4.24

Tab. 9.2.2

For the PJ32 controllers featuring PTC probe input, refer to the table of temperature/resistance values for the CAREL PTC temperature probe.

NOMINAL VALUE: 990Ω at 25 °C

temperature (°C)	R_{min} (Ω)	R_{std} (Ω)	R_{max} (Ω)
-40	545	562	578
0	792	807	820
20	944	952	962
50	1178	1196	1213

Tab. 9.2.3

10. DIMENSIONS

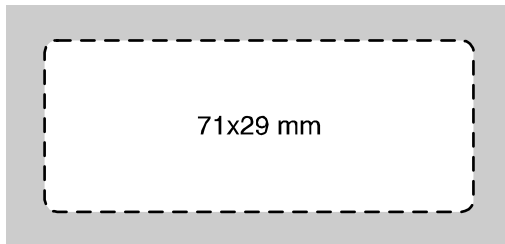
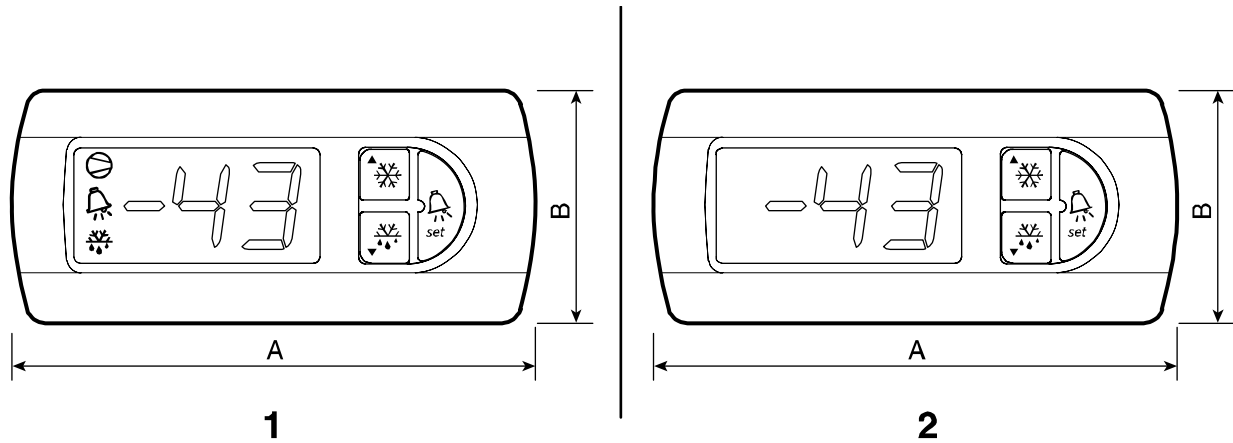

Note: Figures 1 and 2 show the two versions of the instrument. The first shows the status LEDs inside the display area, while the second shows the backlit silicone buttons.

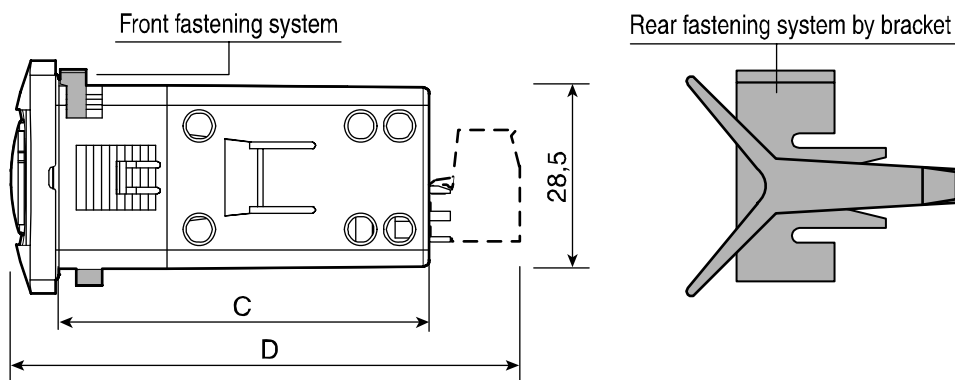

Fig. 10.1

dimensions (mm)	fixed screw terminals	removable terminals
A	81	81
B	36	36
C	68	78
D	65	65

Tab. 10.1

CAREL reserves the right to modify or change its products without prior notice.

CAREL

Technology & Evolution

CAREL S.p.A.
Via dell'Industria, 11 - 35020 Brugine - Padova (Italy)
Tel. (+39) 049.9716611 Fax (+39) 049.9716600
<http://www.carel.com> - e-mail: carel@carel.com

Agency: